

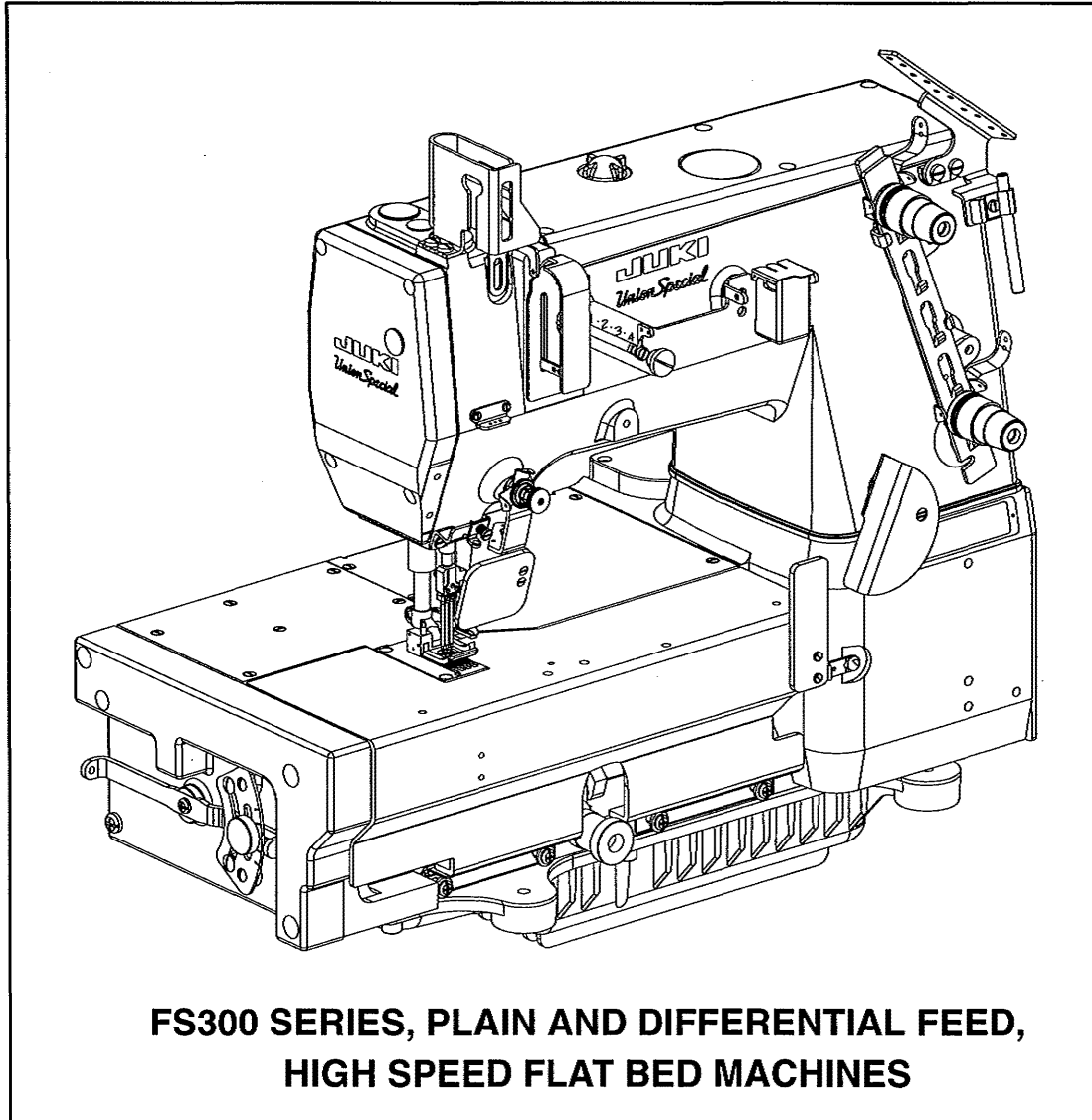

Union Special

INDUSTRIAL SEWING EQUIPMENT

OPERATOR / ILLUSTRATED PARTS MANUAL



**FS300 SERIES, PLAIN AND DIFFERENTIAL FEED,
HIGH SPEED FLAT BED MACHINES**

**MANUAL NO. PT9605
FOR STYLES**

FS311S01	FS311S13
FS311S02	FS311S14
FS311S11	FS311S21
FS311S12	

Manual No. PT9605 Illustrated Parts List for FS300 Series Machines

Second Edition Copyright 1998

By

Union Special Corporation Rights Reserved In All Countries

Printed in U.S.A. Sept. 1998

PREFACE

This parts manual has been prepared to assist you in locating individual parts or assemblies on FS300 Series machines. It can be used in conjunction with Union Special Engineer's Manual EN9424.

It is the desire of Union Special that each machine run at its optimum performance. Parts listed in this manual are designed specifically for your machine and are manufactured with utmost precision to assure long lasting service.

This manual has been comprised on the basis of available information. Changes in design and/or improvements may incorporate a slight modification of configuration in illustrations or part numbers.

On the following pages are illustrations and terminology used in describing the parts used on FS300 Series machines.



CONTENTS

PREFACE	2
IDENTIFICATION OF MACHINES	4
CLASS DESCRIPTION	4
STYLE OF MACHINES	4
ILLUSTRATIONS	5
IDENTIFYING PARTS	5
NEEDLES	5
SAFETY RULES	6
CAUTION AREAS:	8
OPERATOR'S DAILY CHECK LIST:	9
OPERATING CAUTIONS:	9
OPERATING CAUTIONS (CONT.):	10
OPERATING THE PEDALS:	10
LUBRICATION:	11
THREADING THE MACHINE:	12
THREADING THE MACHINE (CONT.):	13
THREADING THE MACHINE (CONT.):	14
THREADING METHODS	14
ADJUSTING THE STITCH LENGTH:	15
PRESSER FOOT PRESSURE AND LIFTER:	15
BUSHINGS	17
NEEDLE BAR	19
UPPER MAIN SHAFT	21
THREAD GUIDE	23
TENSION RELEASE & THREAD TENSION	25
PRESSER FOOT LIFT	27
COVERS, UPPER ARM	29
LOWER MAIN SHAFT	31
LUBRICATION, OIL TUBING & OIL PUMP	33
LOOPER DRIVE	35
NEEDLE GUARD	37
LOOPER THREAD TAKE-UP	39
FEED DRIVE MECHANISM FOR PLAIN FEED	41
FEED DRIVE MECHANISM FOR DIFFERENTIAL FEED	43
FEED DRIVE MECHANISM FOR PLAIN FEED	45
FEED DRIVE MECHANISM FOR DIFFERENTIAL FEED	47
COVERS, LOWER BED	49
COVERS, LOWER BED FOR PLAIN FEED	51
COVERS, LOWER BED FOR DIFFERENTIAL FEED	53
SEWING PARTS	55
TABLING AND NEEDLE DIPPER ASSEMBLY (EXTRA SEND CHARGE)	57
ACCESSORIES	59
NUMERICAL INDEX OF PARTS	60
NUMERICAL INDEX OF PARTS	61
NOTES	62
NOTES	63



IDENTIFICATION OF MACHINES

Each UNION SPECIAL machine is identified by a style number, which is stamped into the style plate affixed to the middle of the machine under the tension assembly. The serial number is stamped into the serial number plate affixed to the right rear base of the machine.

CLASS DESCRIPTION

Precision high speed, single needle, plain or differential feed flat bed machines. Totally enclosed feed and looper drive mechanism, automatic forced feed lubrication system with easily replaceable filter. Main feed has thumbscrew adjustment and differential feed has lever adjustment and independently driven rear needle guard.

STYLE OF MACHINES

FS311S01-1M	SEAMER. One needle, plain feed, medium capacity. Needle thread ratio index furnished. - Typical Application - For seaming side and inseams on work and dress pants. Seam Specifications 401SSa-1. Recommended needle 128 GBS sizes 075/029 - 090/036. Stitch range 7-10 S.P.I.. Maximum recommended speed 6500 R.P.M..
FS311S01-1MCC2	SEAMER. Same as style FS311S01-1M, except with Power "Air Klipp" Chain Cutter.
FS311S02-1M	SEAMER. Same as style FS311S01-1M, except foot with left yielding section. - Typical Application - For side-seaming trousers when crossing front pockets.
FS311S02-1MCC2	SEAMER. Same as style FS311S02-1M, except with Power "Air Klipp" Chain Cutter.
FS311S11-1M	"FEEDING FOOT" SEAMER. Same as style FS311S01-1M, except with "Feeding Foot". - Typical Application - For seaming trousers, coats etc..
FS311S11-1MCC2	"FEEDING FOOT" SEAMER. Same as style FS311S11-1M, except with Power "Air Klipp" Chain Cutter.
FS311S12-1M	"FEEDING FOOT" SEAMER. Same as style FS311S11-1M, except foot with left yielding section. - Typical Application - For side-seaming trousers when crossing front pockets.
FS311S12-1MCC2	"FEEDING FOOT" SEAMER. Same as style FS311S12-1M, except with Power "Air Klipp" Chain Cutter.
FS311S13-1M	"FEEDING FOOT" SEAMER. Same as style FS311S11-1M, except with NARROW "FEEDING FOOT". - Typical Application - For seaming trousers, coats, panels for baseball caps and similar operations. Recommended needle 128 GBS sizes 070/027 - 080/032.
FS311S13-1MCC2	"FEEDING FOOT" SEAMER. Same as style FS311S13-1M, except with Power "Air Klipp" Chain Cutter.
FS311S14-1M	"LOW INERTIA FOOT" SEAMER. Same as style FS311S01-1M, except "Low Inertia" presser foot. - Typical Application - For seaming side and inseam trousers.
FS311S14-1MCC2	"LOW INERTIA FOOT" SEAMER. Same as style FS311S14-1M, except with Power "Air Klipp" Chain Cutter.
FS312S21-1M	DIFFERENTIAL FEED "LOW INERTIA FOOT" SEAMER. Same as style FS311S14-1M, except tandem differential feed.
FS312S21-1MCC2	DIFFERENTIAL FEED "LOW INERTIA FOOT" SEAMER. Same as style FS312S21-1M, except with Power "Air Klipp" Chain Cutter.



ILLUSTRATIONS

This manual has been arranged to simplify ordering repair parts. Exploded views of various sections of the mechanism are shown so that the parts may be seen in their actual position in the machine. On the page opposite the illustration will be found a listing of the parts with their part numbers, description and the number of pieces required in the particular view being shown.

Numbers in the first column are reference numbers only, and merely indicate the position of the part in the illustration. The reference number should never be used in ordering parts. Always use the part number listed in the second column.

Component parts of sub-assemblies which can be furnished for repairs are indicated by indenting their descriptions under the description of the main sub-assembly. As an example refer to the following text.

5.	50366B	Needle Thread Strike-Off Assembly	1
6.	50358V	Needle Thread Strike-Off	1
7.	50370F	Thread Strike-Off Component	1
8.	SS7060310SP	Screw, for plate strike-off	1

When a part is common to all machines covered in this manual, no specific usage will be mentioned in the description. However, when the parts for the various machines are not the same, the specific usage will be mentioned in the description and, if necessary, the difference will be shown in the illustration.

*Ref. No. showing no Part No. is for location only. Part is not for sale separately.

A numerical index of all the parts shown in this manual is located at the back. This will facilitate locating the illustration and description when only a part number is known.

IDENTIFYING PARTS

Where construction permits, each part is stamped with its part number. On some of the smaller parts and on those where construction does not permit, an identification letter is stamped in to distinguish the part from similar ones.

PLEASE NOTE: Part numbers represent the same part, regardless of which manual they appear. On all orders please include part number, name and style of machine for which the part was ordered.

For optimum performance use only genuine Union Special replacement parts.

NEEDLES

Each needle has both a type and size number. The type number denotes the kind of shank, point, length, groove, finish and other details. The size number, stamped on the needle shank, denotes the largest diameter of the blade measured between the shank and the eye. Collectively, the type number and size number represent the complete symbol which is given on the label of all needles packed and sold by Union Special.

<u>TYPE</u>	<u>DESCRIPTION</u>
128 GBS	Short, double groove, struck groove, ball eye, spotted, ball point, chromium plated- Sizes available 070/027, 075/029, 080/032, 090/036.

When changing the needle, make sure it is fully inserted in the needle holder before the screw is tightened.

When ordering needles, please use the complete type and size numbers as printed on the package to ensure prompt and accurate processing of your order. A complete order should read as follows: "100 needles, type 128 GBS, size 075/029".



SAFETY RULES

1. Before putting the machines described in this manual into service, carefully read the instructions. The starting of each machine is only permitted after taking notice of the instructions and by qualified operators.

IMPORTANT! Before putting the machine into service, also read the safety rules and instructions from the motor supplier.

2. Observe the national safety rules valid for your country.
3. The sewing machines described in this instruction manual are prohibited from being put into service until it has been ascertained that the sewing units which these sewing machines will be built into, have conformed with the EC Council Directives (89/392/EEC, Annex II B).

Each machine is only allowed to be used as foreseen. The foreseen use of the particular machine is described in paragraph "STYLES OF MACHINES" of this instruction manual. Another use, going beyond the description, is not as foreseen.

4. All safety devices must be in position when the machine is ready for work or in operation. Operation of the machine without the appertaining safety devices is prohibited.
5. Wear safety glasses.
6. In case of machine conversions and changes all valid safety rules must be considered. Conversions and changes are made at your own risk.
7. The warning hints in the instructions are marked with one of these two symbols:



8. When doing the following the machine has to be disconnected from the power supply by turning off the main switch or by pulling out the main plug:
 - 8.1 When threading needle(s), looper, spreader etc.
 - 8.2 When replacing any parts such as needle(s), presser foot, throat plate, looper, spreader, feed dog, needle guard, folder, fabric guide etc.
 - 8.3 When leaving the workplace and when the workplace is unattended.
 - 8.4 When doing maintenance work.
 - 8.5 When using clutch motors without actuation lock, wait until the motor is stopped totally.
9. Maintenance, repair and conversion work (see item 8) must be done only by trained technicians or special skilled personnel under consideration of the instructions.
10. Any work on the electrical equipment must be done by an electrician or under direction and supervision of special skilled personnel.
11. Work on parts and equipment under electrical power is not permitted. Permissible exceptions are described in the applicable sections of standard sheet DIN VDE 0105.
12. Before doing maintenance and repair work on the pneumatic equipment, the machine has to be disconnected from the compressed air supply. In case of existing residual air pressure, after disconnecting from compressed air supply (i.e. pneumatic equipment with air tank), the pressure has to be removed by bleeding.

FS300 SERIES BUILDING BLOCK STYLE DESIGNATION SYSTEM

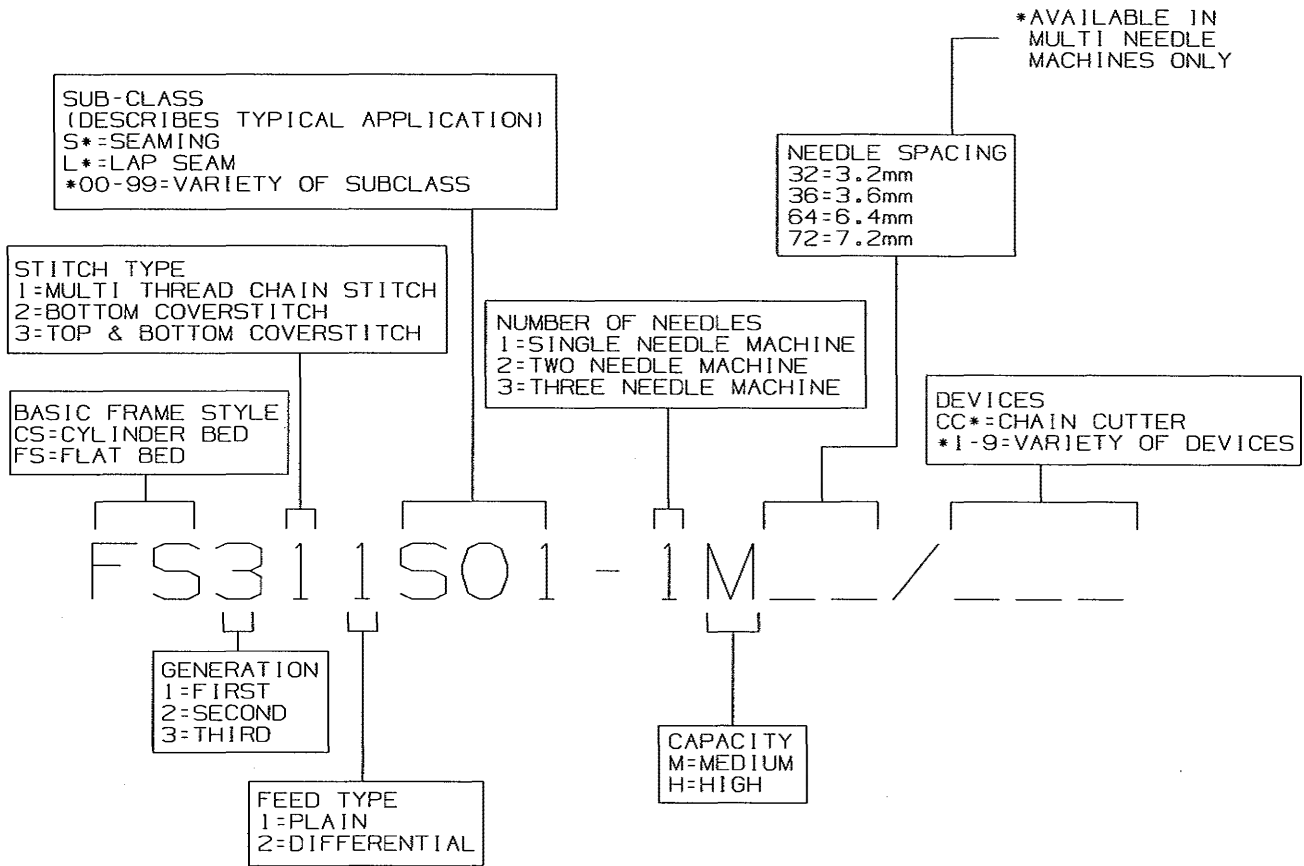

CAUTION AREAS:

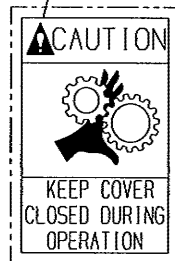
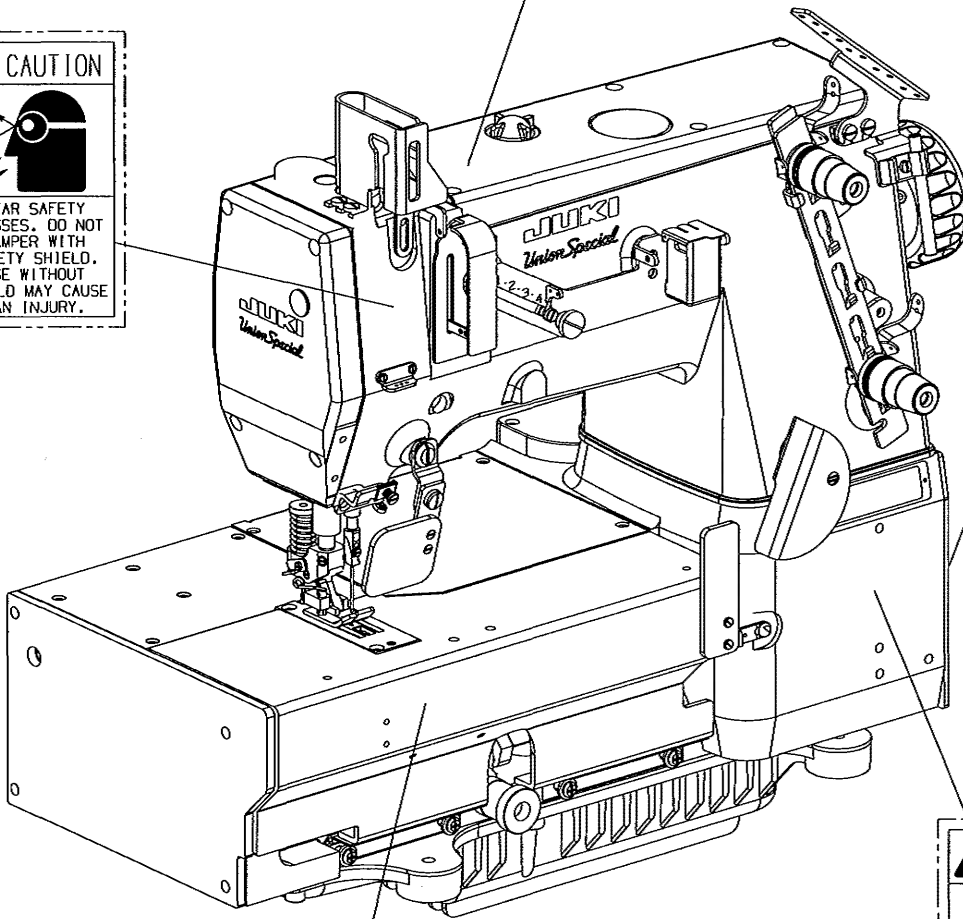
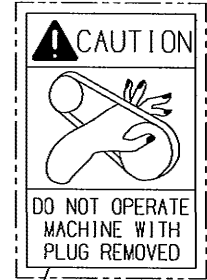

OPERATOR'S DAILY CHECK LIST:

The following should be checked daily and cleaned as required when it applies to your Union Special machine:

- Oil flow
 - Oil level
 - Lint area (clean with compressed air or brush)
 - Needle bar bushings
 - Under feed dogs & throat plates
 - In knives
 - In thread control eyelets
 - Cooling airways
 - In the machine
 - In the motor
 - In the cooling package
- (package is an extra send charge)

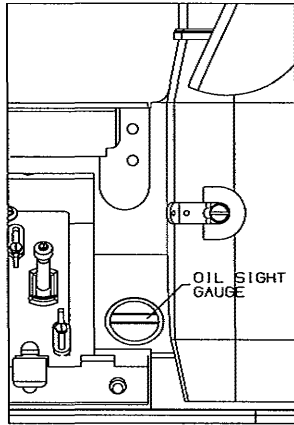

1. The oil level in the sight gauge should be between the two red lines when the machine is at rest. If not, fill with Union Special Specification 175 oil, (Union Special Part No. 28604R).

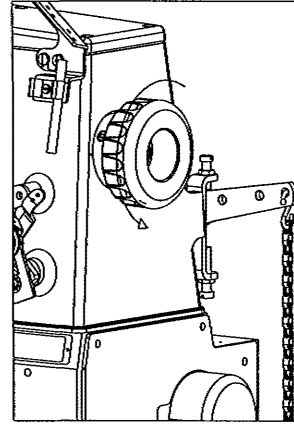

2. The correct rotating direction of the handwheel is counterclockwise, as viewed from the handwheel's side. NEVER run the machine in reverse direction.

OPERATING CAUTIONS:

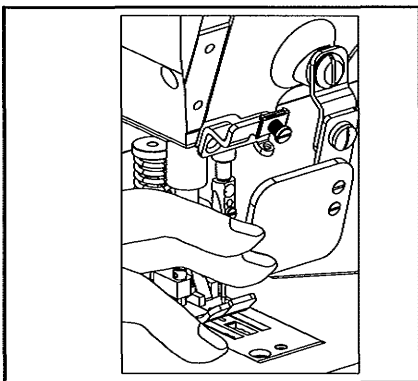

1. Do not put your hand under the needles when turning on the power switch or at any time.

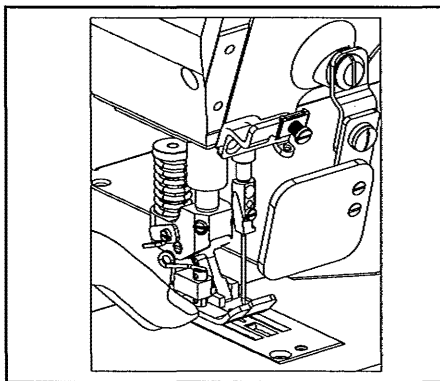

2. Do not put your hand into the sewing area while the machine is running.

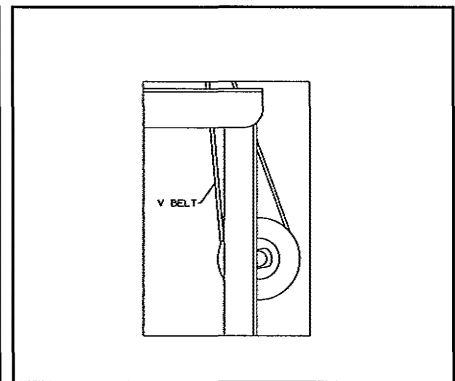

3. Turn off the power switch and make sure the clutch motor is at rest before removing the V belt.



OPERATING CAUTIONS (CONT.):



4. During operation, do not allow head, hands or any instrument, tool etc. near handwheel, V belt and motor.
 5. Do not operate your machine without the proper belt guard, sewing guards or any other protectors that have been provided. Doing so is very dangerous.
 6. Before inspecting, adjusting, cleaning, threading the head or replacing needles, turn OFF the power switch. Make sure the flywheel on the motor has stopped, it will be kept running by inertia after turning OFF the power switch. DO NOT depress the foot pedal while the machine is running or it will cause the machine to rotate abruptly.
 7. Turn OFF the power switch when you leave your machine or in case of a power failure.
 8. Do not wipe the machine surface with lacquer thinner.
-

OPERATING THE PEDALS:

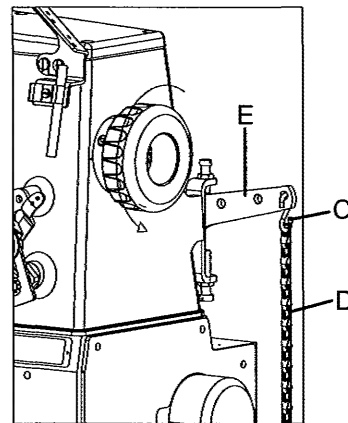
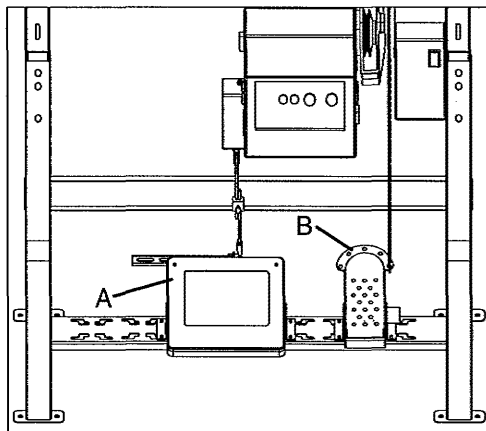

1. Locate the center of drive treadle (A) to be in line with the needles.
2. Locate presser lifter pedal (B) for operator comfort.
3. Use S-shaped hook (C) to connect presser lifter pedal chain (D) to presser lifting lever (E).



LUBRICATION:

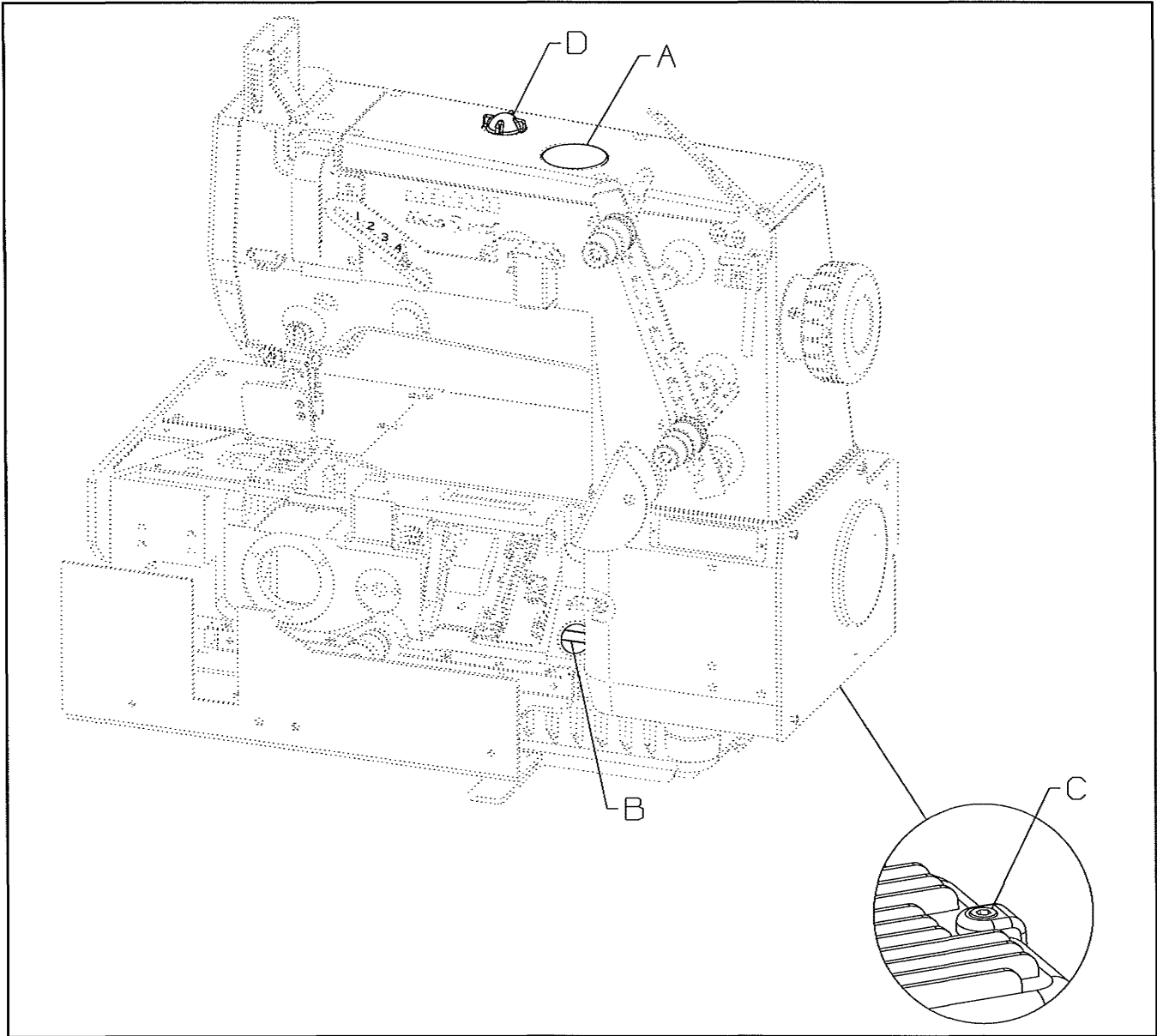

The oil should be between the two red lines in sight gauge (B) when the machine is at rest.

1. If oil is required remove oil cap (A).
2. Fill between lines (B) with Union Special Specification 175 oil (Union Special Part No. 28604R).



CAUTION! Do not exceed the upper red marker line. Excessive oil in the machine will result in oil leakage and possible overheating.

3. To drain oil reservoir, remove oil drain cap (C) on the underside of the machine.
4. To ensure oil flow through machine, check oil flow window (D).

THREADING THE MACHINE:



Turn off main power switch before threading! When using clutch motors without actuation lock wait until the motor has completely stopped.

Thread the machine according to the following threading illustrations.

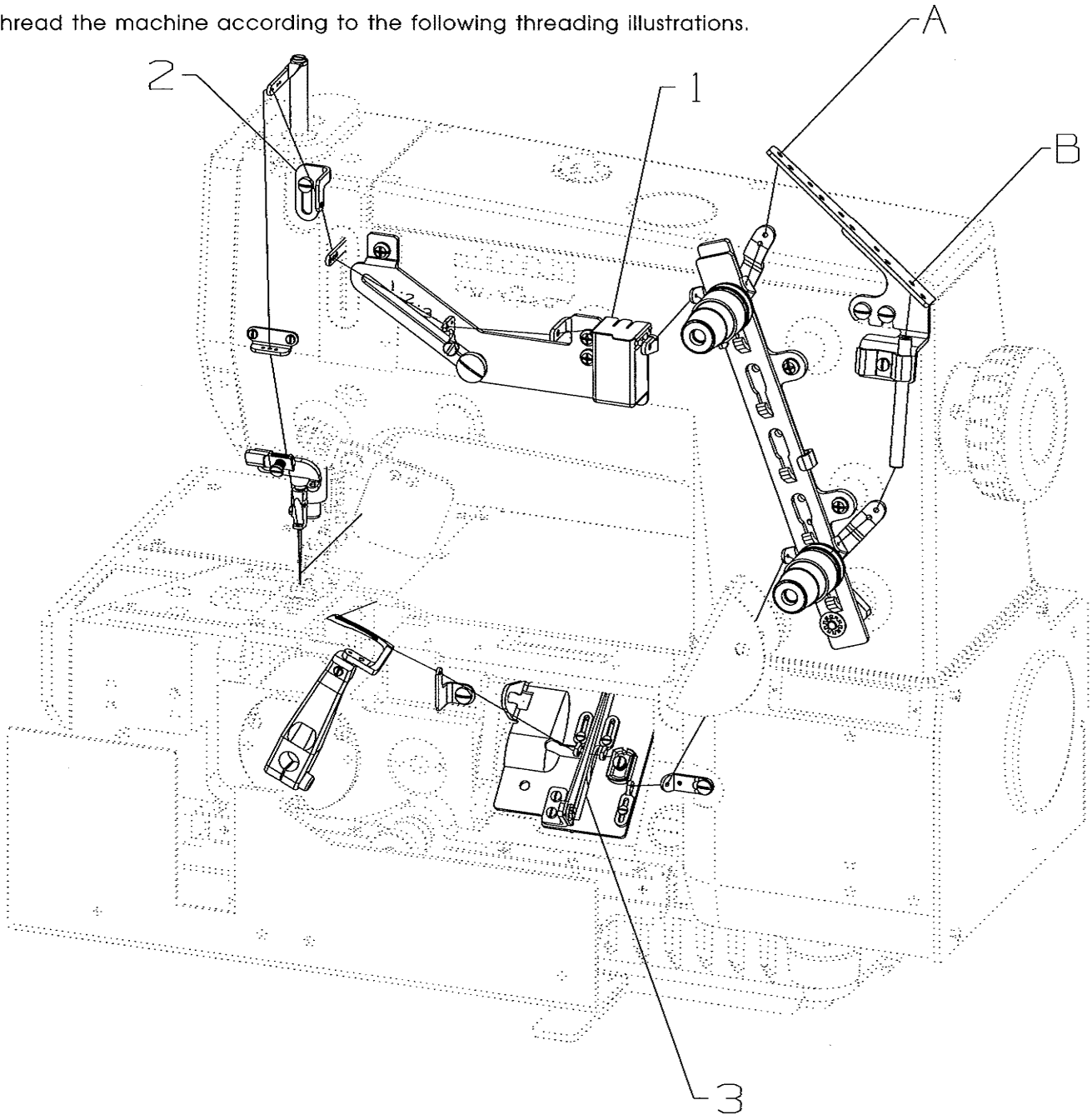

A Left Needle Thread
B Looper Thread

1 Thread Lubricator Area
2 Needle Bar Area
3 Thread Take-Up Area



THREADING THE MACHINE (CONT.):

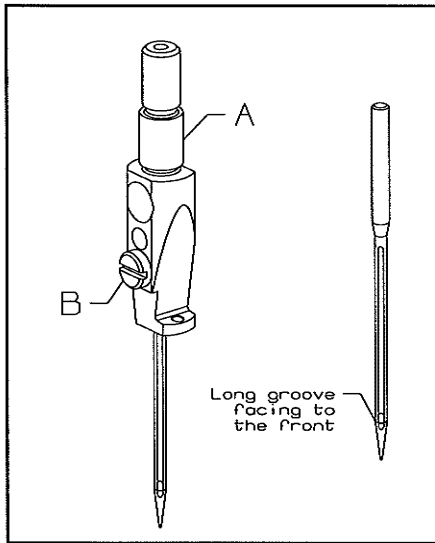

The standard needle is 128 GBS, needle range sizes "070/027 - 090/036."

Insert needle according to the following procedure:

1. Bring needle head (A) to the highest position.
2. Loosen screw (B), insert needle into holes. The needle scarf should face rearwards as viewed from the operator's side.
3. Retighten screw (B).

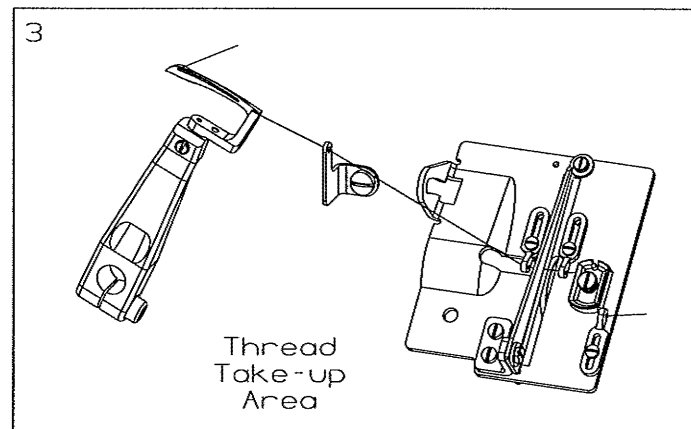
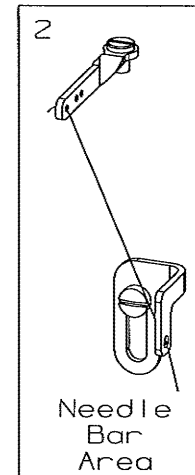
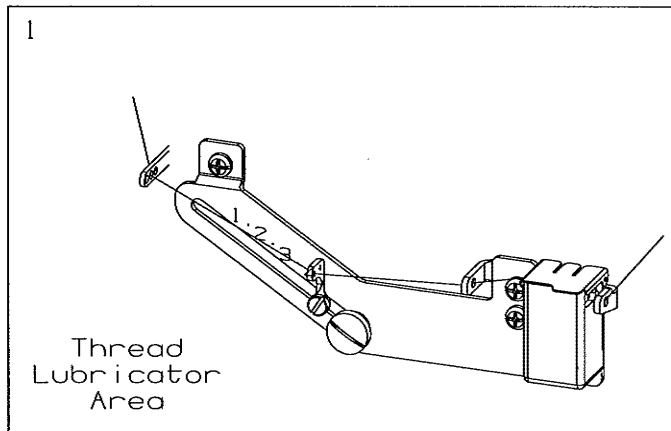

THREADING THE MACHINE (CONT.):

When the needle thread lubricator is used:

1. Saturate felt (A).
2. Pass thread over felt.

When the needle thread lubricator is not used:

1. Remove felt (A).

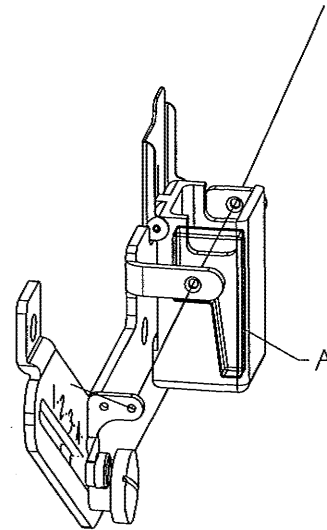

THREADING MEDTHODS



CAUTION!

When using an untwisted thread such as wooly nylon or weak thread, do not wind it around the intermediate thread guide.

Twisted Thread

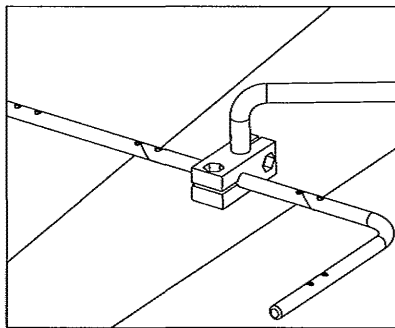

Non-Twist Thread

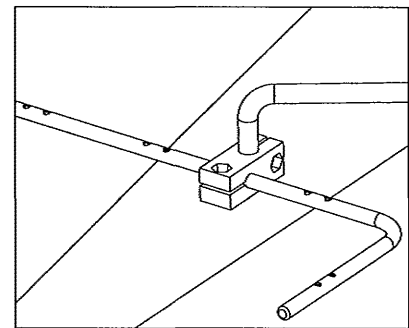

PRESSER FOOT PRESSURE AND LIFTER:

1. Adjust presser foot pressure by loosening nut (A) and turning presser foot adjust screw (B) clockwise to increase the pressure, counterclockwise to decrease the pressure.
2. Retighten nut (A).

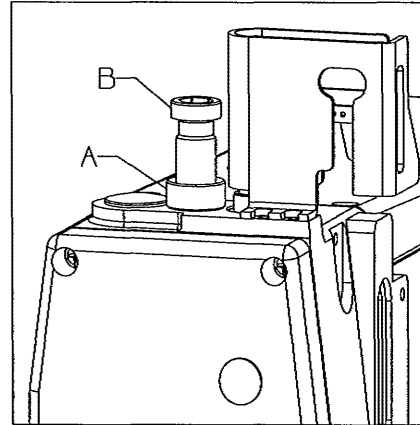

ADJUSTING THE STITCH LENGTH:



Turn off main power switch before setting the stitch length! When using clutch motors without actuation lock wait until the motor has completely stopped.

1. To change stitch length turn stitch regulating screw (A).

Clockwise to increase the stitches per inch/shorten the length of one stitch.

Counterclockwise to decrease stitches per inch/increase the length of one stitch.

2. Numbers 0-11 on stitch regulating screw are for operator's reference only.

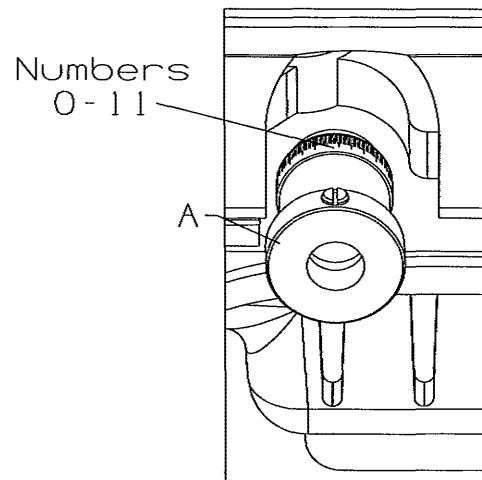

DIFFERENTIAL FEED MECHANISM:

1. Loosen screw (A) and move lever (B) up for gathering (+) and down (-) for stretch.
2. Retighten screw (A).
3. When the main stitch travel is set at .078" (2mm) the differential ratio for maximum gather is 1:1.5, maximum stretch is 1:0.6, depending on material.

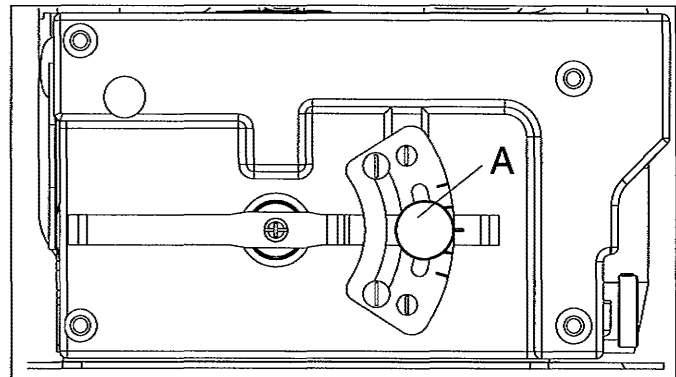

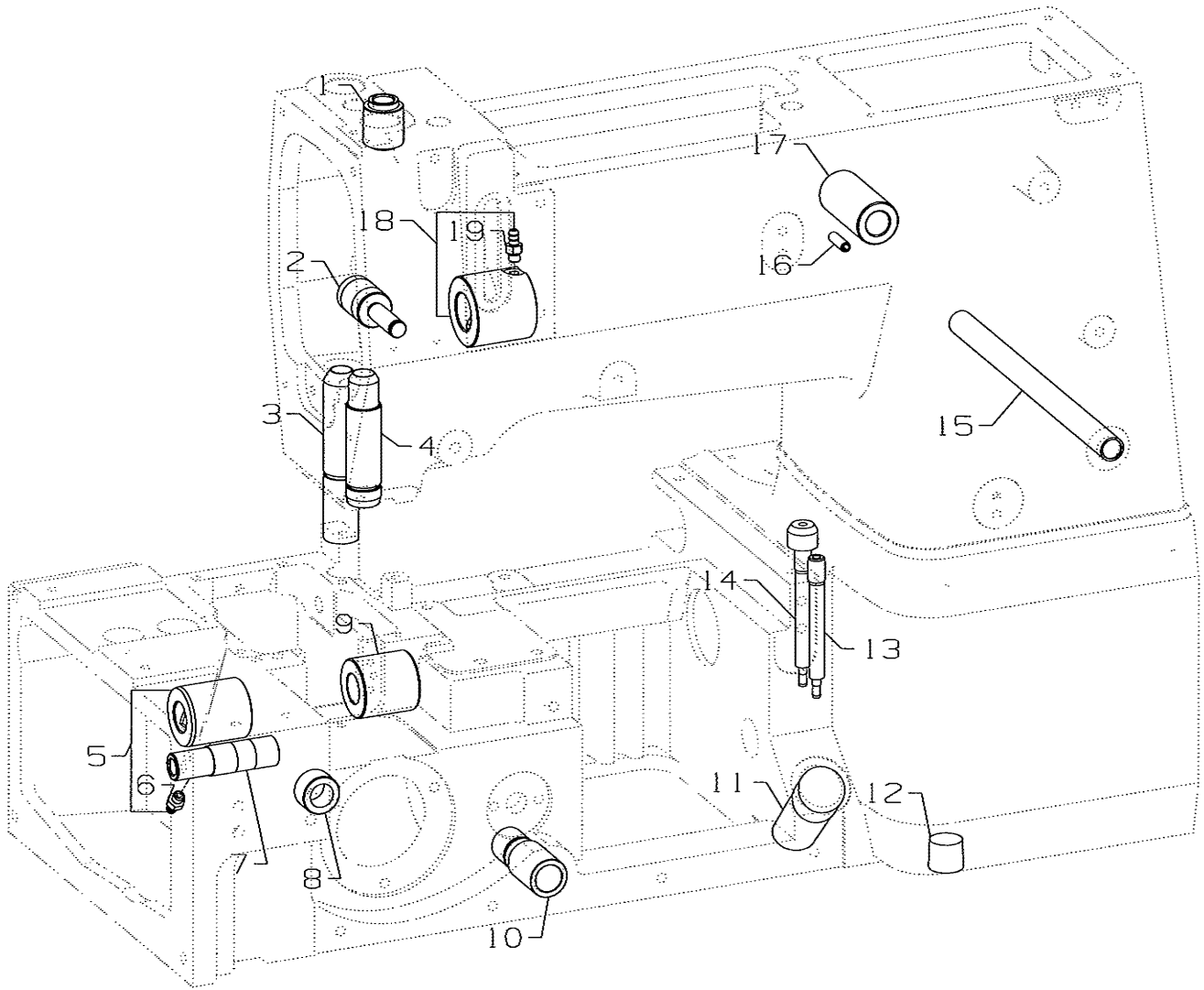

BUSHINGS

Ref. No.	Part No.	Description	Amt. Req.
1.	50654	Bushing, for needle bar, upper	1
2.	50332U	Pin, for front lifter lever	1
3.	50330CZ	Bushing, for presser bar	1
4.	50654A	Bushing, for needle bar, lower	1
5.	50344BE	Bushing, for lower mainshaft, left	1
6.	SQ1110401MZ	Fitting	1
7.	50344BC	Bushing, for needle lever	1
8.	50344E	Bushing	1
9.	50344BF	Bushing, for lower mainshaft, right	1
10.	35036BS	Stitch Regulator Bushing	1
11.	50393GE	Oil Sight Gauge	1
12.	22571L	Screw, for drain plug	1
13.	50393FU	Fitting, oil tube	1
14.	50393EY	Fitting, filter	1
15.	50392AB	Bushing, for tension release.....	1
16.	PS0400142KH	Pin	1
17.	50381E	Bushing, for lifter lever, back	1
18.	50344BU	Bushing, front	1
19.	SQ1110401MZ	Fitting	1



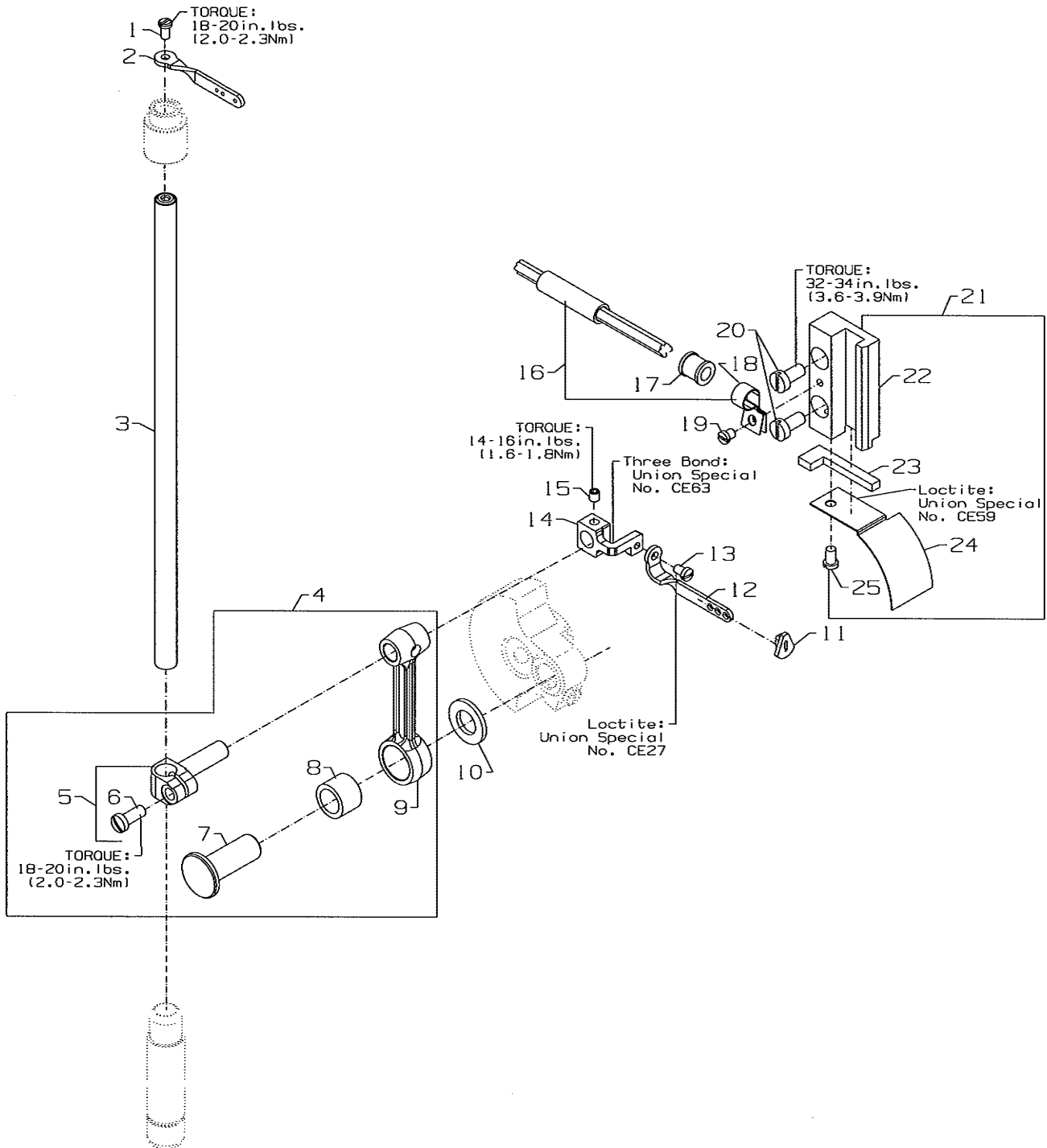

NEEDLE BAR

Ref. No.	Part No.	Description	Amt. Req.
1.	SS4080620TP	Screw	1
2.	50323P	Needle Bar Eyelet	1
3.	50317B	Needle Bar	1
4.	50345W	Connecting Rod Assembly	1
5.	50355AM	Needle Bar Clamp	1
6.	SS7111120TP	Screw	1
7.	50352	Pivot Pin	1
8.	661-259B	Needle Bearing Cage	1
9.	50355AN	Connecting Rod	1
10.	50351A	Washer	1
11.	50393JP	Eyelet Seal	1
12.	50358X	Needle Thread Eyelet	1
13.	SS7080520SP	Screw	1
-	CE27	Loctite Adhesive, (not shown), for screw	-
14.	50354F	Slide Block	1
-	CE63	Three Bond Adhesive, (not shown), for slide block	-
15.	SS8110422TP	Screw	1
16.	29476TC	Oil Tube Assembly	1
17.	50393JZ	Oil Tube	1
18.	50393JW	Hose Clamp	1
19.	SS6090440SP	Screw, for oil tube assembly	1
20.	SS6121010SP	Screw	2
21.	29476VN	Slide Block Guide and Cover Assembly	1
22.	50338	Guide, for slide block	1
23.	666-328	Felt, for slide block	1
-	CE59	Loctite Adhesive, (not shown), for felt	-
24.	50338A	Cover, for guide	1
25.	SS6090620SP	Screw	1



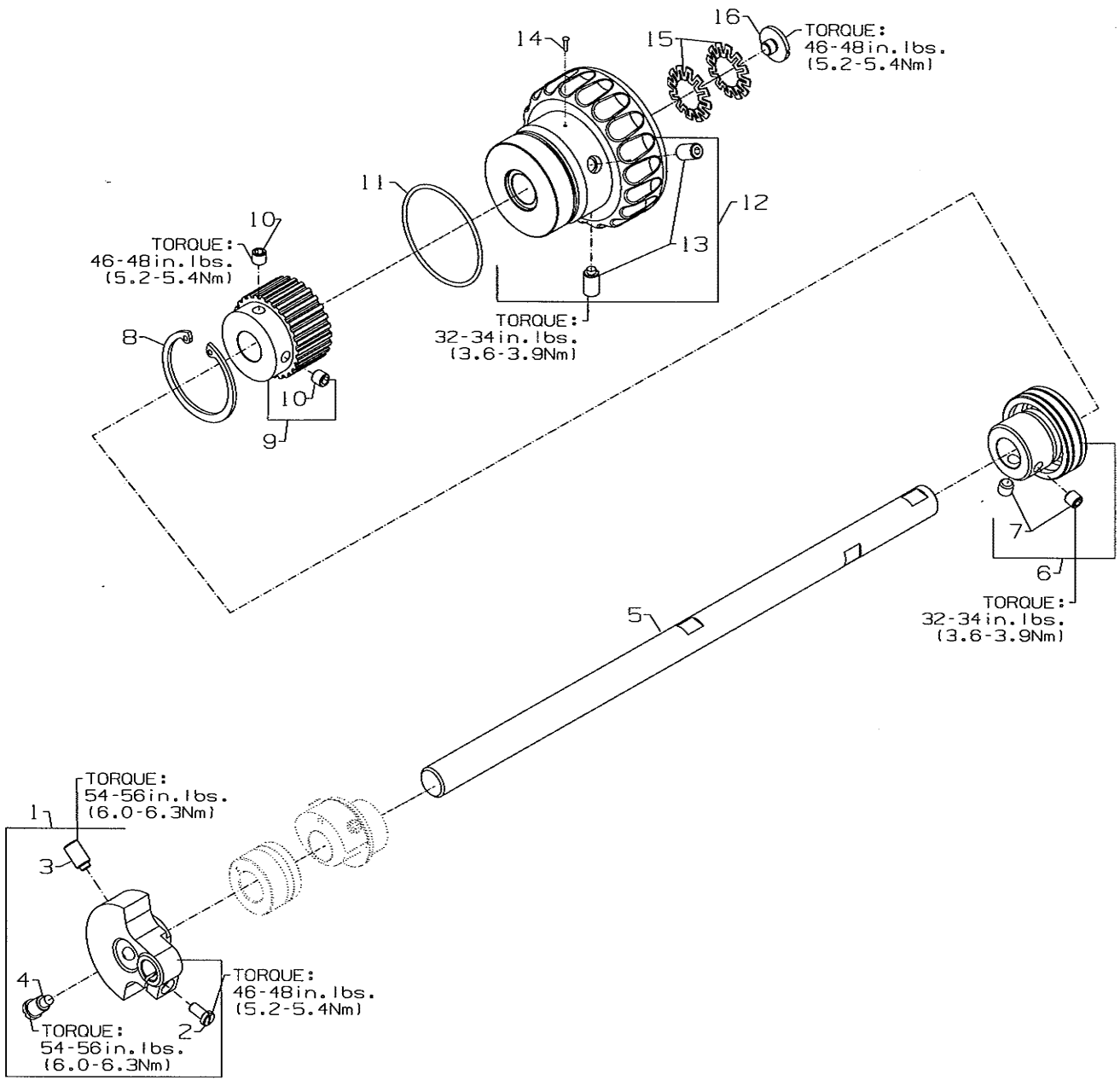

UPPER MAIN SHAFT

Ref. No.	Part No.	Description	Amt. Req.
1.	50391	Counter Weight	1
2.	SS7111120TP	Screw, for counter weight	1
3.	SS8681412TP	Screw, for counter weight	1
4.	SS7681410TP	Screw, for counter weight	1
5.	50322AF	Upper Main Shaft	1
6.	50335BD	Bearing Adapter Assembly	1
7.	SS8660612TP	Screw, for bearing adapter	2
8.	661-262	Retaining Ring	1
9.	50342BE	Sprocket, for upper main shaft	1
10.	SS8661012TP	Set Screw, for sprocket	2
11.	660-1087	"O" Ring.....	1
12.	50321F	Handwheel	1
13.	SS8681412TP	Set Screw, for handwheel	2
14.	660-1043	Tack Pin, for handwheel	1
15.	661-261	Load Ring, for lower main shaft	2
16.	SS7660520SP	Screw, for handwheel preload	1



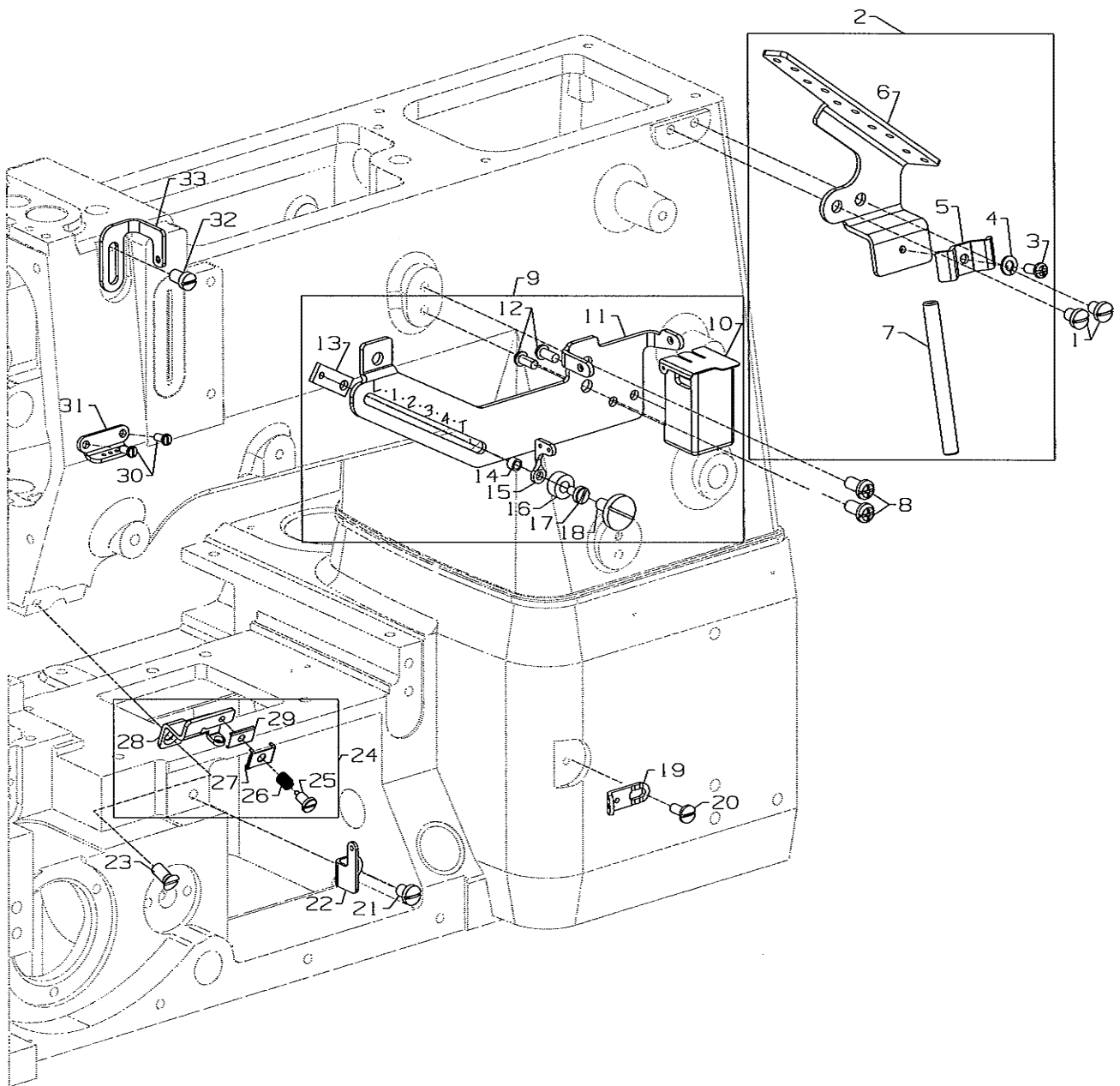

THREAD GUIDE

Ref. No.	Part No.	Description	Amt. Req.
1.	SS7120640SP	Screw, for lead-in eyelet	2
2.	50692H	Thread Eyelet Assembly	1
3.	SS7090910TP	Screw	1
4.	WS0410002KP	Split Washer	1
5.	50366A	Thread Eyelet Tube Bracket	1
6.	50392S	Lead-In Tension Eyelet	1
7.	50366	Thread Eyelet Tube	1
8.	SS4120915SP	Screw, for spreader thread guide	2
9.	29476TG	Thread Ratio Control Assembly	1
10.	50393HH	Silicone Thread Lubricator	1
11.	50683A	Thread Control Bracket	1
12.	SS4090815SP	Screw, for silicone tank	2
13.	56358B	Guide Block	1
14.	56358C	Guide	1
15.	158B	Thread Eyelet	1
16.	56358D	Washer	1
17.	98A	Screw	1
18.	22837	Screw	1
19.	12124202	Looper Frame Eyelet	1
20.	SS70906105SP	Screw	1
21.	SS7120640SP	Screw	1
22.	50392AE	Looper Frame Eyelet	1
23.	SS1121010SP	Screw, for thread guide	1
24.	50357AR	Nipper Plate Assembly	1
25.	SD0380551SL	Screw	1
26.	50357AS	Nipper Spring	1
27.	50357Y	Nipper Spring Plate	1
28.	50366G	Thread Guide	1
29.	50357V	Nipper Plate	1
30.	605A	Screw, for needle thread guide	2
31.	C50044E	Needle Thread Guide	1
32.	SS7120710SP	Screw, for strike-off	1
33.	50663	Needle Thread Strike-Off Eyelet	1



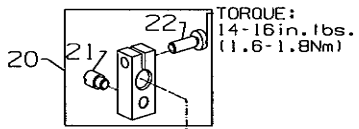

TORQUE:
14-16 in. lbs.
(1.6-1.8 Nm)

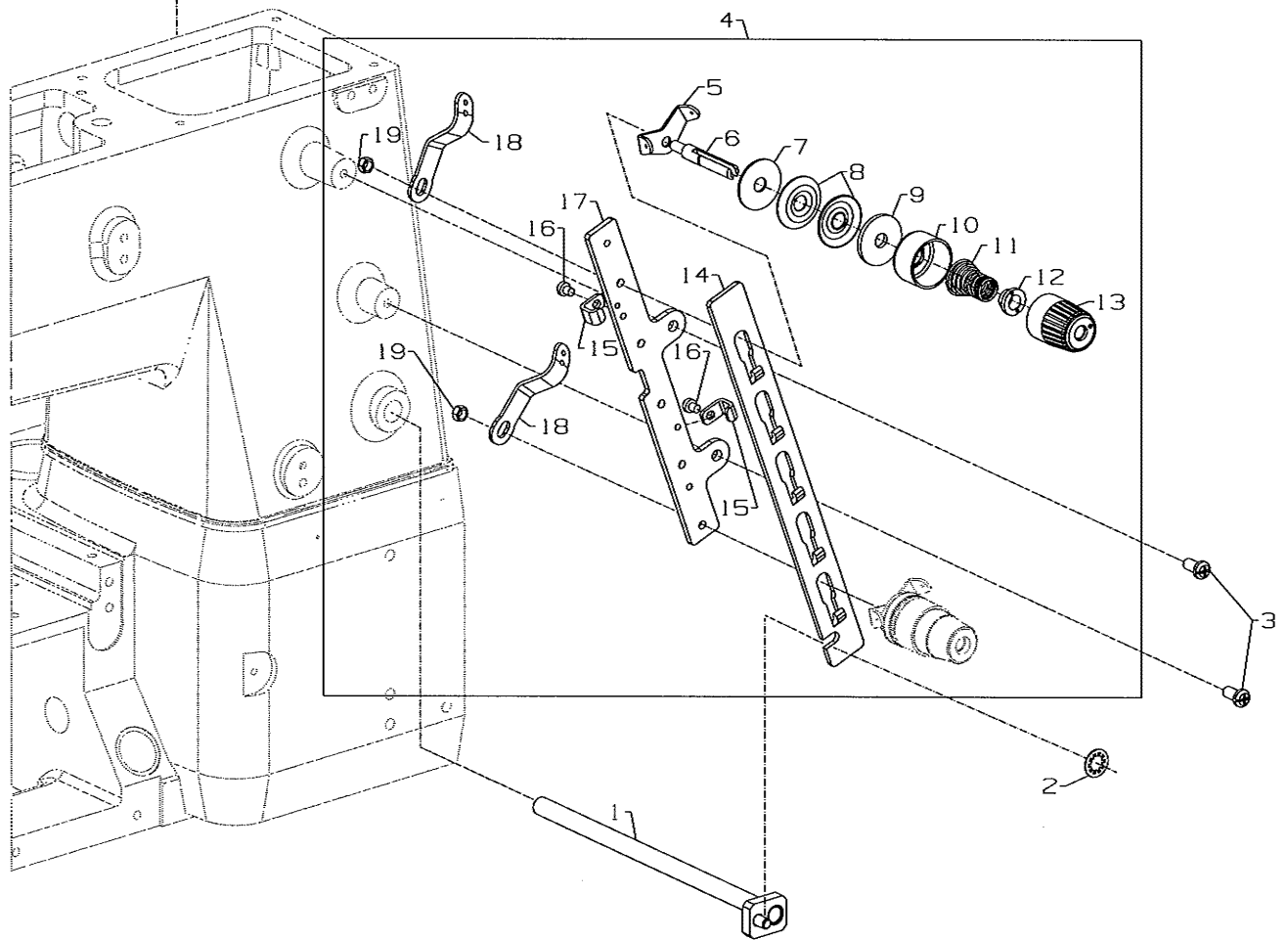

TENSION RELEASE & THREAD TENSION

Ref. No.	Part No.	Description	Amt. Req.
1.	50392Z	Tension Needle Lever Assembly	1
2.	660-283A	Retainer Washer	1
3.	SS4120915SP	Screw, for tension assembly	2
4.	50692B	Two Thread Tension Assembly	1
5.	57892K	Thread Tension Eyelet	2
6.	56392G	Tension Post	2
7.	B3120352000	Tension Disc Felt	2
-	666-330	Disc Felt	4
8.	B3126012000	Tension Disc	4
9.	B3120704000	Tension Disc Felt	2
10.	56392H	Spring Shield	2
11.	11550209	Spring, needle (green)	3
-	B3103804000	Spring, spreader (blue)	1
-	B3121804000	Spring, looper (plain)	1
12.	B3112704000	Ferrule, tension spring	2
13.	50692G	Knob, needle (green)	3
-	56392R	Knob, looper (plain)	1
14.	50392W	Tension Disc Separator	1
15.	50392AV	Guide, for tension disc separator	2
16.	SS7090520SP	Screw, for guide	2
17.	50392X	Tension Bracket	1
18.	57865	Lead-In Thread Guide	2
19.	NS6110420SP	Nut	2
20.	50392BC	Tension Release Lever Shaft Connection	1
21.	22875N	Stop Screw	1
22.	SS7121410TP	Binder Screw	1



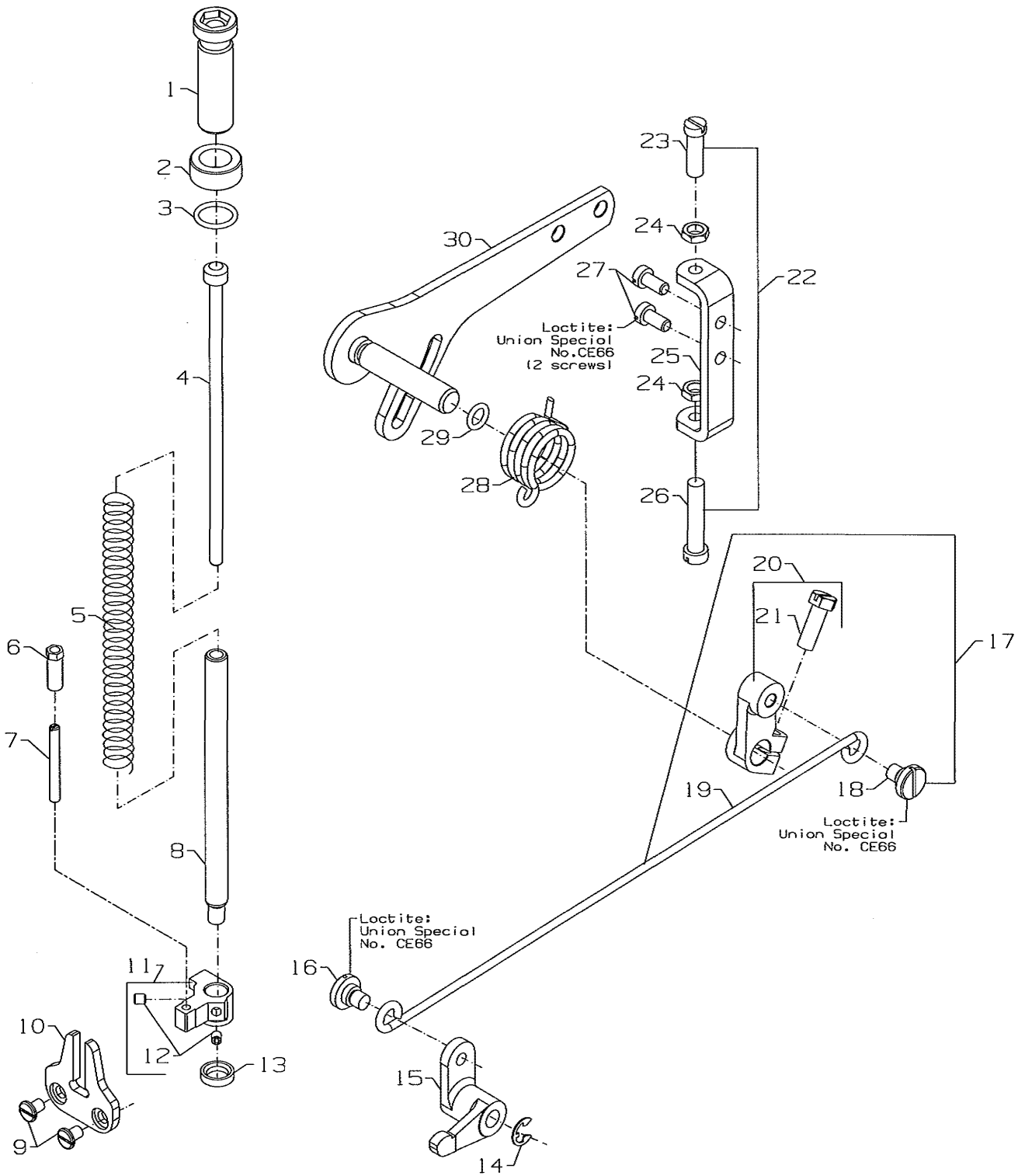

PRESSER FOOT LIFT

Ref. No.	Part No.	Description	Amt. Req.
1.	11071602	Adjusting Screw, for spring	1
2.	11071701	Locking Nut	1
3.	660-1014	"O" Ring	1
4.	C50056B	Spring Rod	1
5.	50357AA	Spring, for presser bar, for S01, S02 machine styles	1
-	50357AP	Spring, for presser bar, for differential feed machines	1
6.	C50056J	Lock Nut	1
7.	50643B	Screw	1
8.	50335AF	Presser Bar, for S01, S02 machine styles	1
-	50643A	Pressr Bar	1
9.	SS6110610TP	Screw, for guide plate	2
10.	50335AG	Guide Plate, for presser bar	1
11.	50335AH	Presser Bar Guide	1
12.	SS8110422TP	Set Screw	2
13.	660-739	Oil Seal	1
14.	RE0500000KO	E Ring, for pin	1
15.	50381F	Lever, for lifter, front	1
16.	SD0790303SP	Screw, for wire connector	1
-	CE49	Loctite Adhesive, (not shown), for screw	-
17.	29476TK	Rear Lifter Lever Assembly	1
18.	SD0790303SP	Screw, for lifter lever assembly	1
19.	50355AR	Wire Connector	1
20.	50381G	Lifter Lever, rear	1
21.	SS9151740CP	Hex Screw	1
22.	29476TT	Stop Assembly	1
23.	SS6151920SP	Screw, for adjusting stopper	1
24.	NS6150310SP	Hex Nut	2
25.	50332V	Stopper, for lifter lever	1
26.	SS6153040SP	Screw, for adjusting stopper	1
27.	SS4121215SP	Screw, for stopper	2
-	CE49	Loctite Adhesive, (not shown), for screw	-
28.	50381	Spring, for lifter lever	1
29.	RO068190100	"O" Ring	1
30.	50381B	Lifter Lever Assembly	1



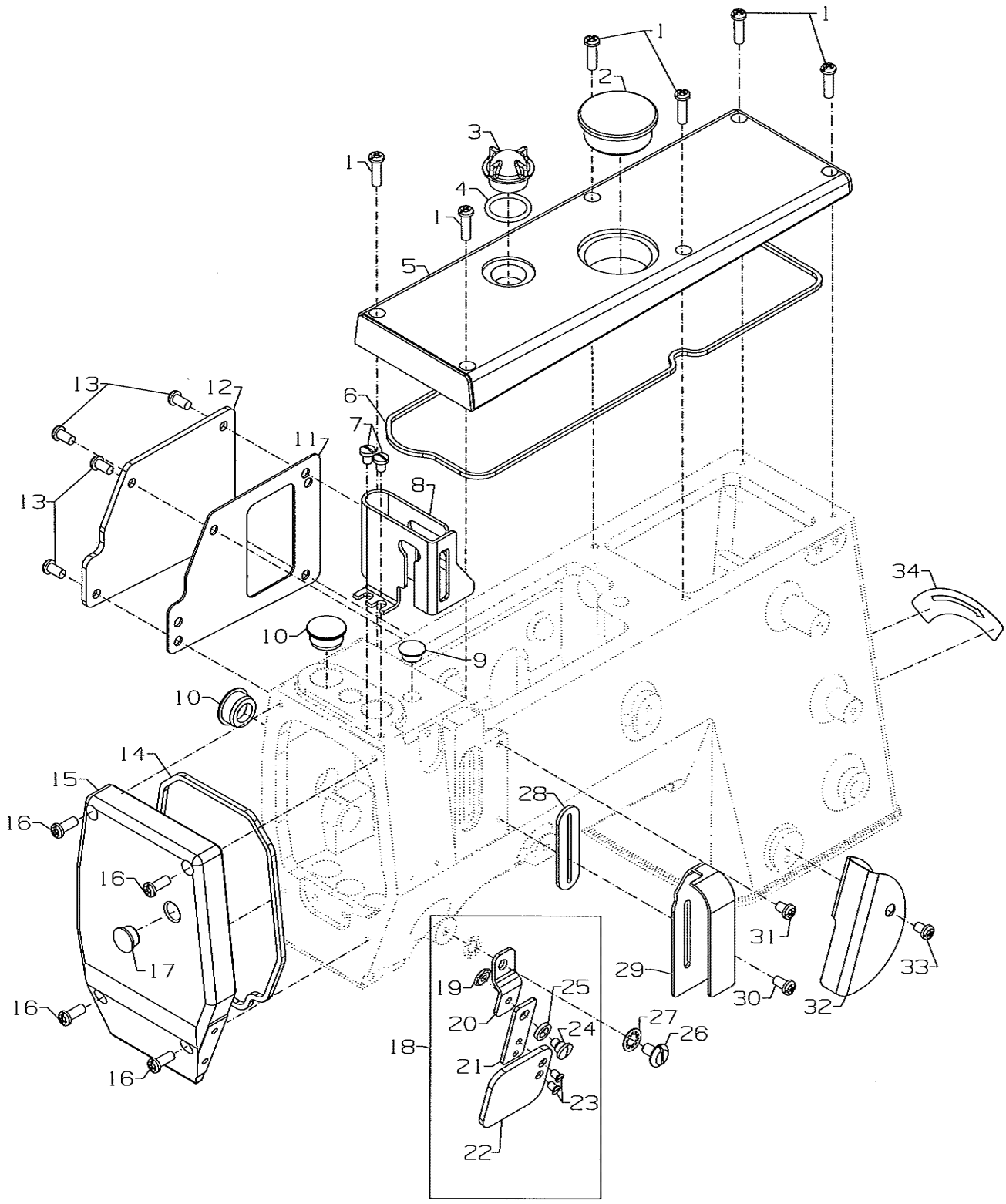

COVERS, UPPER ARM

Ref. No.	Part No.	Description	Amt. Req.
1.	SS4121615SP	Screw, for top cover	6
2.	50393EU	Plug, for top cover	1
3.	B3530555000	Oil Sight Gauge, top	1
4.	660-212	"O" Ring, for oil sight gauge	1
5.	50382FW	Top Cover	1
6.	50382FZ	Quad Ring, for top cover	1
7.	SS7120640SP	Screw, for needle bar guard	2
8.	50317C	Needle Bar Guard	1
9.	TA1050504RO	Plug, for bed	1
10.	50393HB	Plug, for bed	2
11.	50384L	Gasket, for puller drive cover	1
12.	50382GB	Puller Drive Cover	1
13.	SS4120915SP	Screw, for puller drive cover	4
14.	50382FY	Quad Ring, for head cover	1
15.	50382FX	Head Cover	1
16.	SS4121215SP	Screw, for head cover	4
17.	TA1100604RO	Plug, for head cover	1
18.	99682XCB	Protection Shield Assembly	1
19.	NS6620320SP	Nut	1
20.	50383AE	Bracket Holder	1
21.	50383AD	Bracket	1
22.	99682XC	Protection Shield	1
23.	SS1110640SL	Counter Sunk Head Screw	2
24.	SD0640323TP	Shoulder Screw	1
25.	WZ0641510KP	Spring Washer	1
26.	22517B	Screw	1
27.	652C16	Washer	1
28.	50393EW	Rubber Gasket, for needle lever	1
29.	50696	Cover, for thread take-up	1
30.	SS4120915SP	Screw, for thread take-up cover	1
31.	SS4120615SP	Screw, for thread cover	1
32.	50382GM	Thread Cover	1
33.	SS4120615SP	Screw, for thread take-up cover	1
34.	LA452	Label, direction of rotation	1



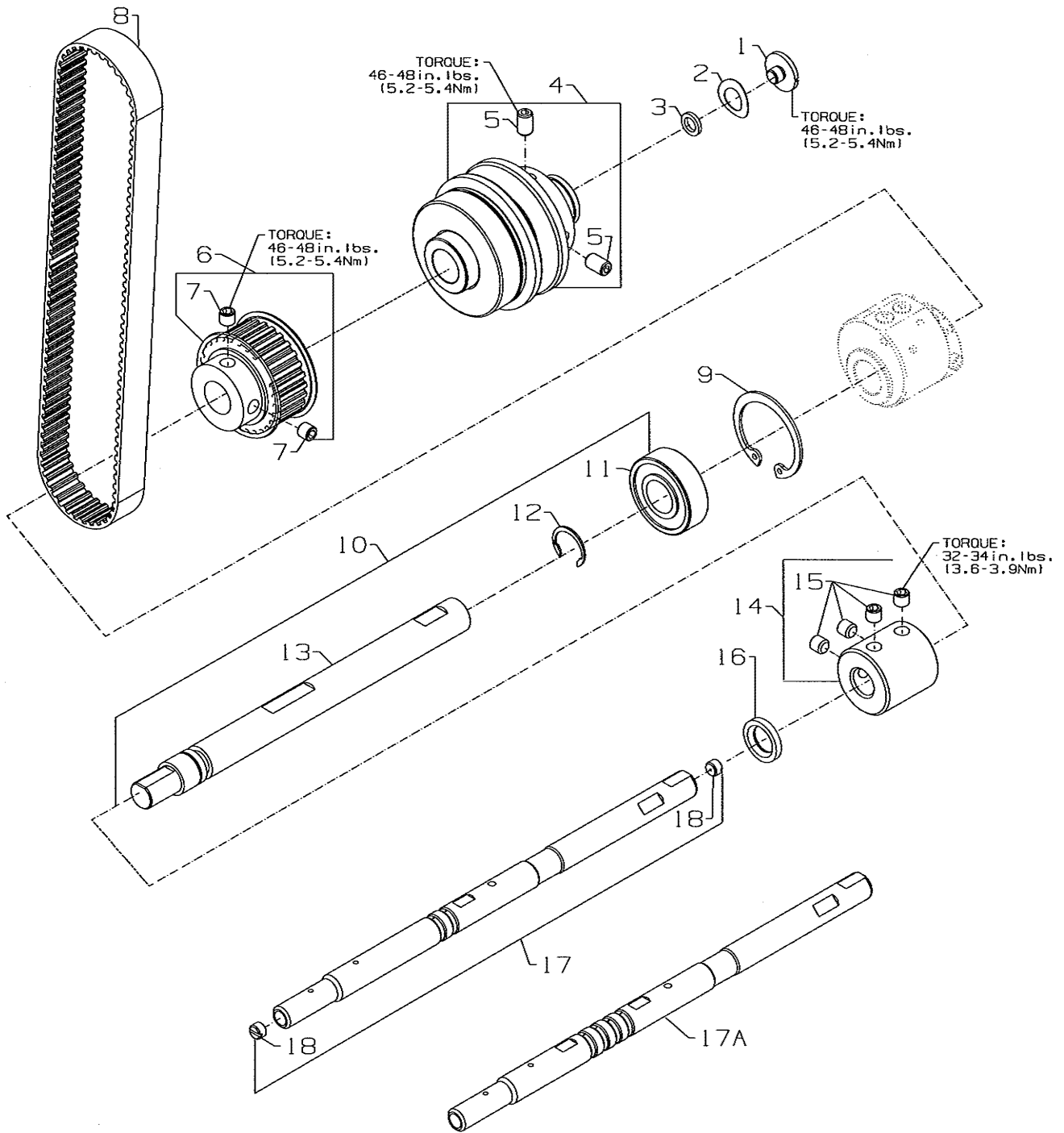

LOWER MAIN SHAFT

Ref. No.	Part No.	Description	Amt. Req.
1.	SS7660520SP	Shoulder Screw, for lower main shaft, right	1
2.	660-1062	Spring Washer	1
3.	50374	Spacer, for pulley assembly	1
4.	50321G	Pulley Assembly	1
5.	SS8661012TP	Set Screw	2
6.	50342AX	Sprocket, for lower main shaft	1
7.	SS8660612TP	Screw	2
8.	50342BS	Timing Belt	1
9.	50335AK	Retaining Ring, for ball bearing	1
10.	29476UH	Mainshaft Assembly, lower, right	1
11.	50322AL	Ball Bearing, for lower main shaft	1
12.	50335BB	Retaining Ring	1
13.	50322AG	Lower Main Shaft, right	1
14.	50333A	Coupling, for lower main shafts	1
15.	SS8660612TP	Screw	4
16.	660-934	Oil Seal	1
17.	50622D	Lower Main Shaft, left for plain feed.....	1
17A.	50622E	Lower Main Shaft, left for differential feed	1
18.	SS8660410SP	Screw	2



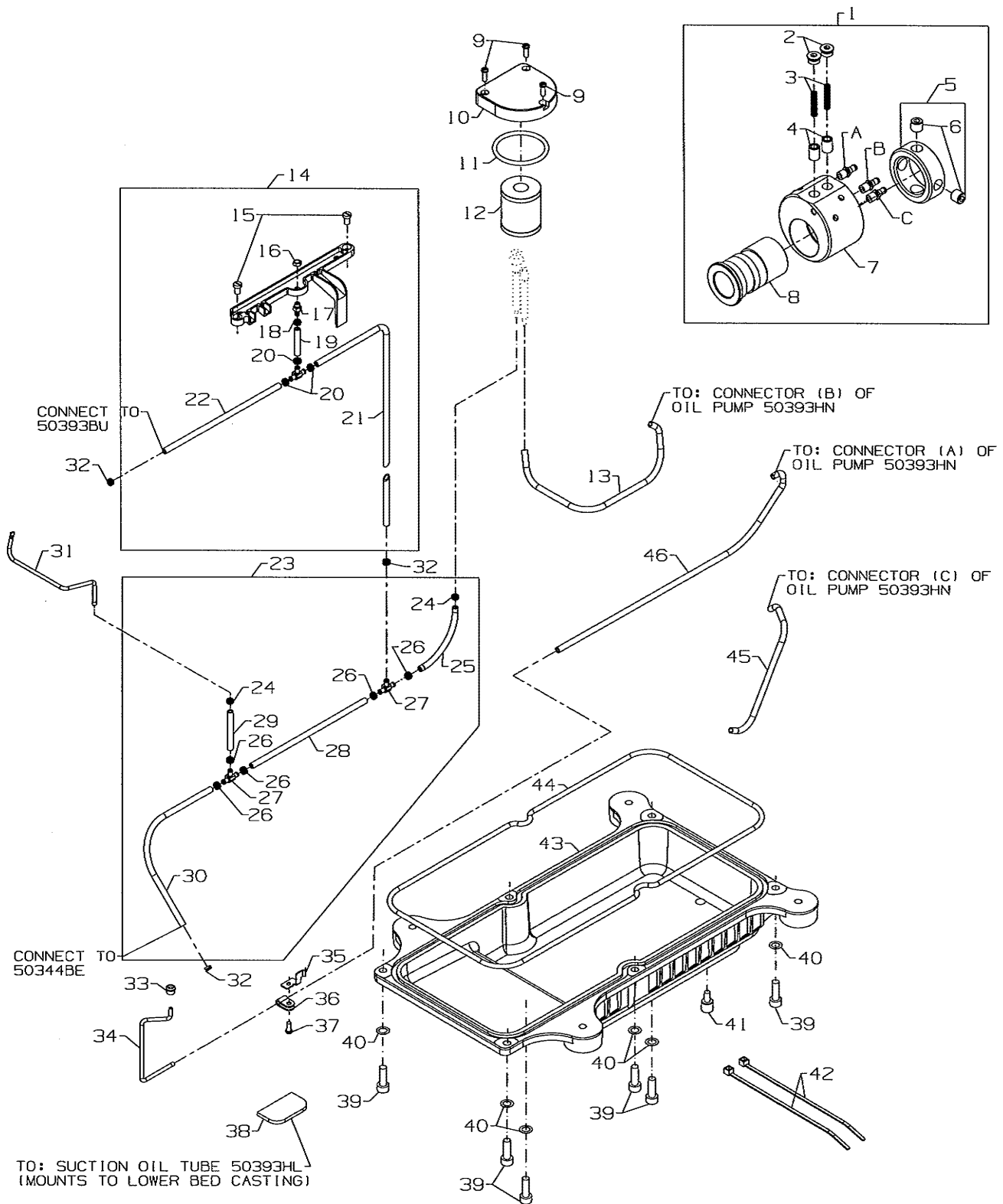

LUBRICATION, OIL TUBING & OIL PUMP

Ref. No.	Part No.	Description	Amt. Req.
1.	50393HN	Oil Pump Assembly, 2-stage	1
2.	SS8660612TP	Screw	2
3.	50332S	Spring, for plunger.....	2
4.	34393D	Plunger.....	2
5.	50393EX	Collar, for oil pump	1
6.	SS8660612TP	Screw	2
7.	50393GB	Oil Pump Housing, 2 Stage.....	1
8.	50393GD	Oil Pump Housing, 2 Stage.....	1
9.	SS4091015SP	Screw, for oil filter cover.....	3
10.	50393FR	Cover, for oil filter.....	1
11.	50384	"O" Ring, for oil filter cover.....	1
12.	11843208	Oil Filter.....	1
13.	50393FV	Oil Tube, for supply (1)	1
14.	29476US	Oil Supply Assembly, upper	1
15.	SS7120710SP	Screw, for front upper tube	2
16.	NS6110310SP	Nut	1
17.	SQ1110402MZ	Fitting	1
18.	50393KH	Tube Retaining, spring	1
19.	50393-27	Oil Tube	1
20.	50393KM	Tube Retaining, spring	3
21.	50393-447	Oil Tube	1
22.	50393-140	Oil Tube	1
23.	29476UT	Oil Supply Assembly, lower	1
24.	50393KH	Tube Retaining, spring	2
25.	50393-70	Oil Tube	1
26.	50393KM	Tube Retaining, spring	5
27.	13765607	"T" Connector	2
28.	50393-140	Oil Tube	1
29.	50393-40	Oil Tube	1
30.	50393-170	Oil Tube	1
31.	50393KF	Oil Tube	1
32.	50393KM	Tube Retaining, spring	3
33.	50393HR	Plug, for feed chamber	1
34.	50393HL	Oil Tube, for suction	1
35.	50393FS	Oil Tube Holder	1
36.	998-358F	Plastic Clip	1
37.	SS4090815SP	Screw, for oil tube holder	1
38.	50393HK	Felt	1
39.	SS6151812TP	Screw, for oil pan	6
40.	WS0631510KP	Spring Washer	6
41.	22571E	Screw, for oil drain plug	1
42.	RM2871B	Cable Tie	2
43.	50393EB	Oil Pan	1
44.	50384A	"O" Ring	1
45.	50393FT	Oil Tube, for suction	1
46.	50393HJ	Oil Tube, for suction	1



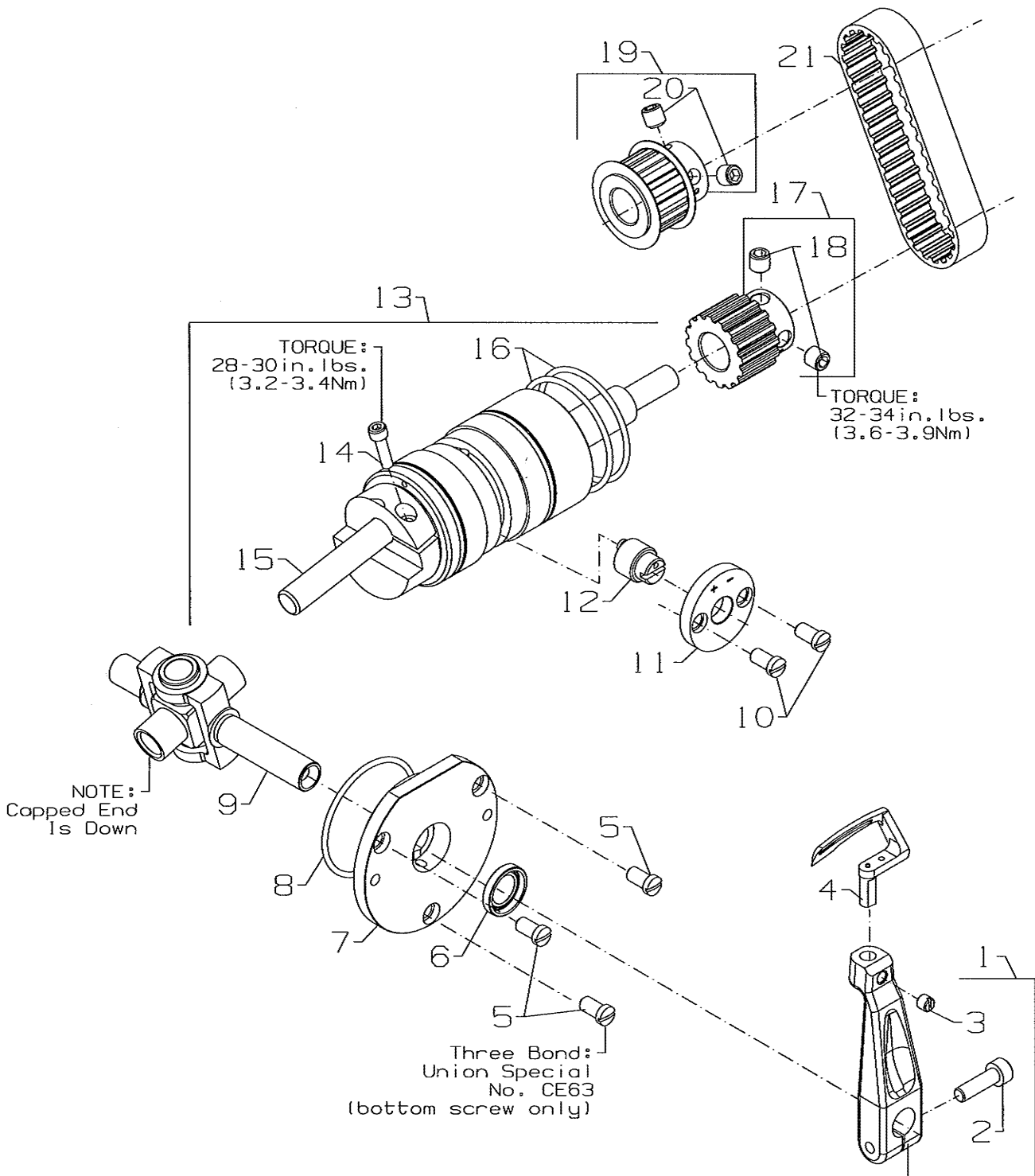

LOOPER DRIVE

Ref. No.	Part No.	Description	Amt. Req.
1.	50313	Looper Holder	1
2.	22652B10	Screw, for looper holder	1
3.	22565	Screw, for looper holder	1
4.	50309F	Looper	1
5.	SS7120910SP	Screw, for bearing housing	3
-	CE63	Three Bond Adhesive, (not shown), for screw	-
6.	660-893	Oil Seal, looper	1
7.	50344AM	Bearing Housing Assembly, for looper drive	1
8.	660-455	"O" Ring, for bearing housing assembly	1
9.	50313J	Looper Rocker Assembly	1
10.	SS7120910SP	Screw, for retaining plate	2
11.	50314F	Eccentric Retaining Plate	1
12.	50314E	Looper Avoid Adjusting Eccentric	1
13.	50642	Looper Drive Assembly	1
14.	22653J8	Screw	1
15.	667J33	Crank Pin	1
16.	660-979	"O" Ring	2
17.	50342BJ	Sprocket, for looper driven	1
18.	SS8660612TP	Screw	2
19.	50342BK	Sprocket, for looper drive	1
20.	SS8660612TP	Screw	2
21.	50342BP	Looper Drive Belt	1



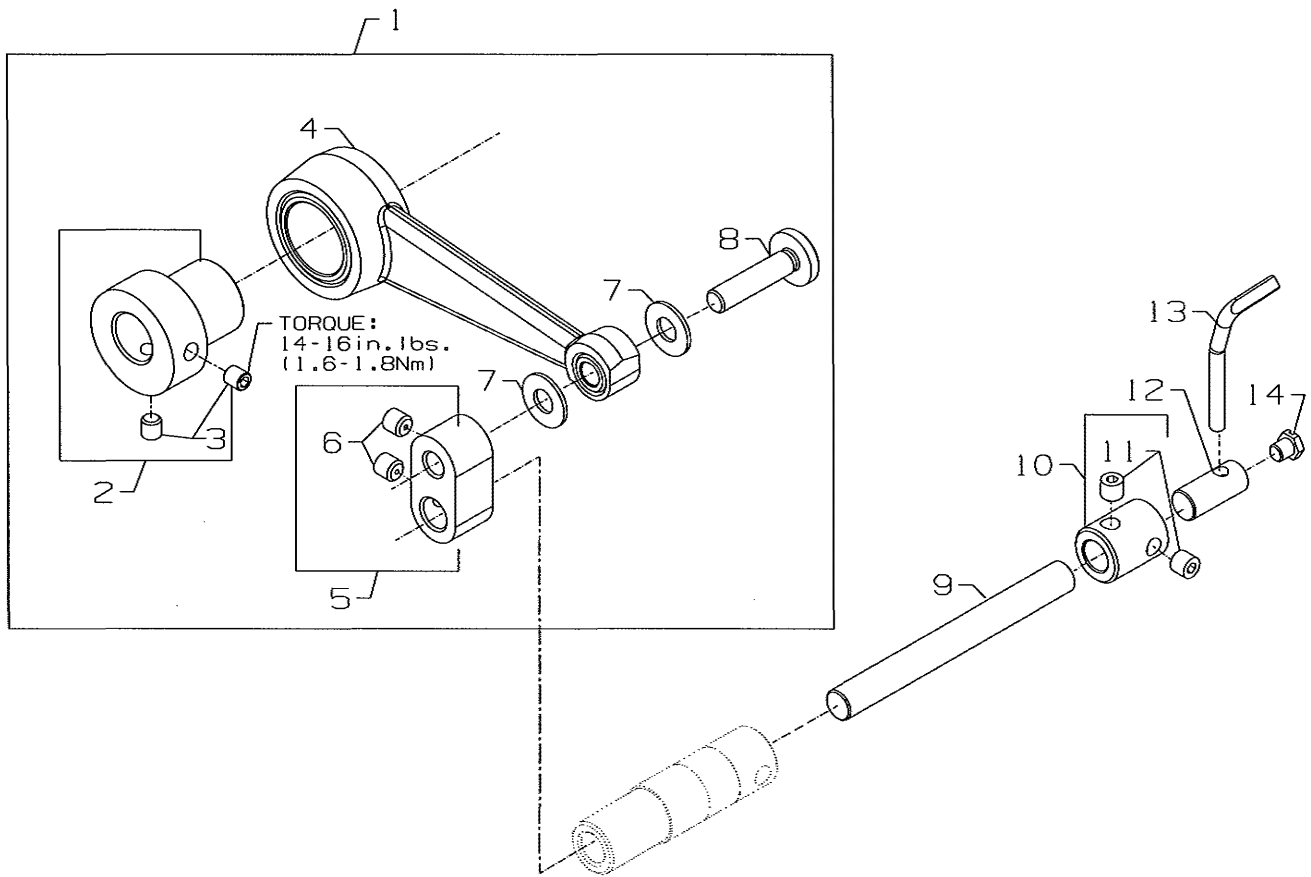

NEEDLE GUARD

Ref. No.	Part No.	Description	Amt. Req.
1.	29476UJ	Rear Needle Guard Drive Assembly	1
2.	50373DA	Needle Guard Eccentric	1
3.	SS8110422TP	Screw, for needle guard eccentric	2
4.	50368W	Connecting Rod Assembly, for needle guard	1
5.	50368T	Pivot Link	1
6.	SS8110422TP	Screw	2
7.	50368E	Washer	2
8.	50368A	Pivot Pin	1
9.	50368V	Shaft, for needle guard	1
10.	50354L	Coupling, for needle guard	1
11.	SS8110422TP	Screw	2
12.	50325AF	Holder, for needle guard	1
13.	50325AE	Needle Guard, rear	1
14.	SS9090420TP	Screw, for rear needle guard	1



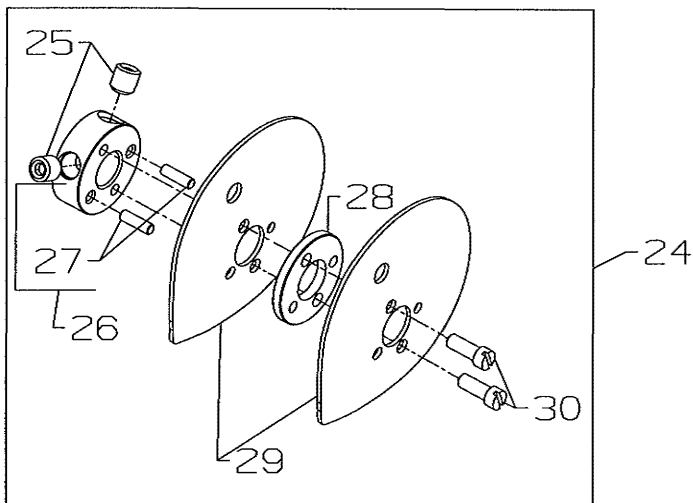
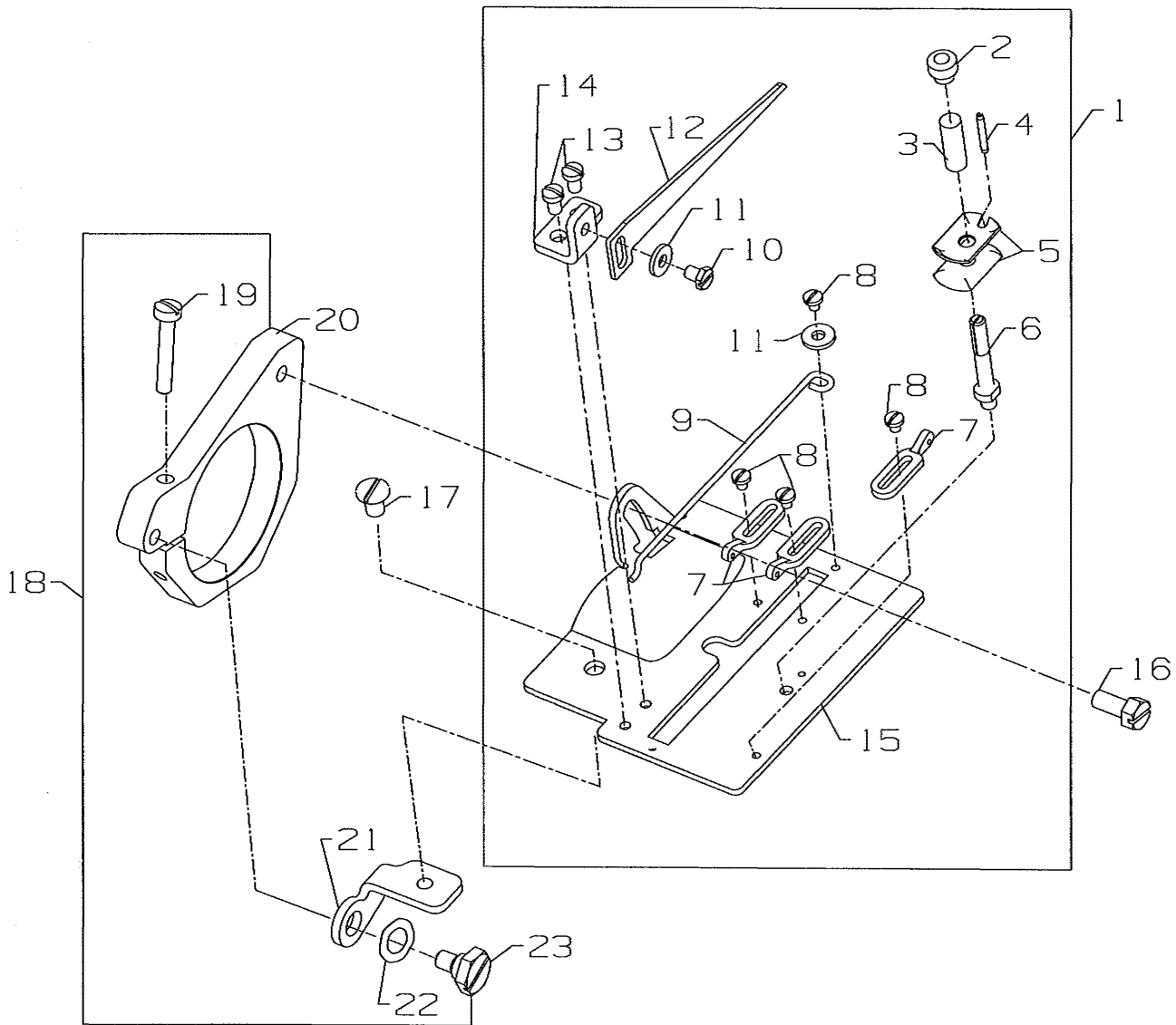

LOOPER THREAD TAKE-UP

Ref. No.	Part No.	Description	Amt. Req.
1.	50657	Cast-Off Plate Assembly	1
2.	51959D	Knurled Nut	1
3.	51959K	Tension Spring	1
4.	51959L	Roll Pin	1
5.	51959B	Tension Disc	2
6.	51492	Tension Post	1
7.	52958D	Take-up Eyelet	3
8.	SS7060310SP	Screw	4
9.	50304H	Strike-Off Wire	1
10.	SS9080410SP	Screw	1
11.	41358	Washer	2
12.	50304L	Retaining Finger	1
13.	SS7080520SP	Screw	2
14.	50383E	Mounting Bracket	1
15.	50357W	Cast-Off Plate	1
16.	SS9111010SP	Screw, for collar bracket	1
17.	SS6110610TP	Screw, for cast-off holder	1
18.	29476UK	Cast-Off Plate Holder Assembly	1
19.	SS7092110TP	Screw, for collar bracket	1
20.	50383F	Take-up Collar Bracket	1
21.	50304K	Cast-Off Plate Holder	1
22.	WZ0640200KP	Washer	1
23.	SD0630275SP	Shoulder Screw, for cast-off plate holder	1
24.	50623	Take-up Assembly	1
25.	22894C	Set Screw	2
26.	50323B	Take-up Hub	1
27.	22-348	Pin	2
28.	50377R	Spacer	1
29.	50323H	Disc, for take-up	2
30.	77B	Screw, for take-up disc	2



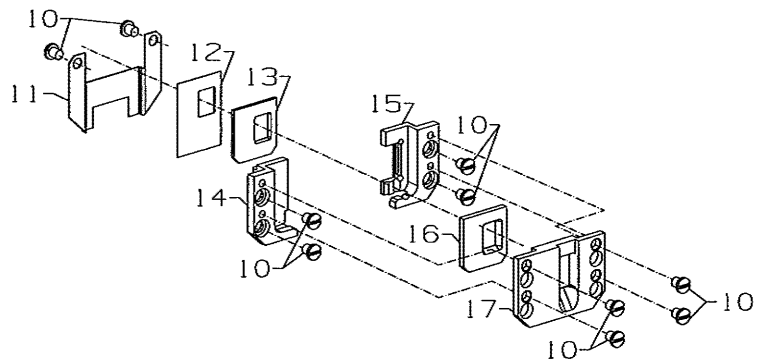
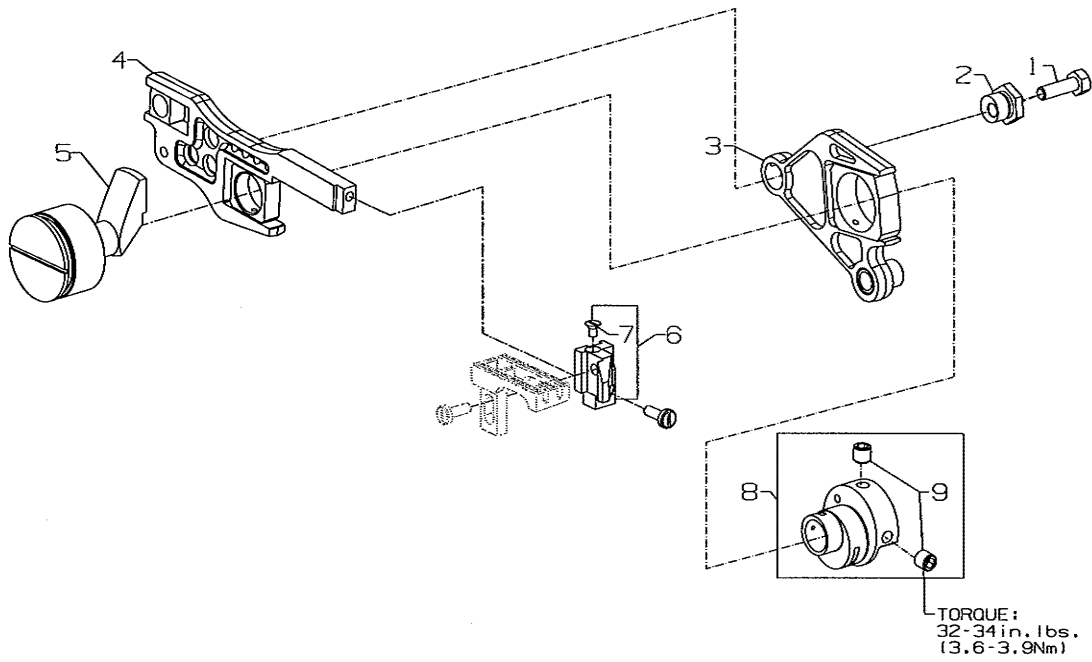

FEED DRIVE MECHANISM
FOR PLAIN FEED

Ref. No.	Part No.	Description	Amt. Req.
1.	18-1432	Screw.....	1
2.	50334BD	Hex Eccentric Stud	1
3.	50334AX	Drive Fork Assembly, right	1
4.	50634	Feed Bar Assembly	1
5.	50334A	Plain Feed Bar Guide	1
6.	50634E	Feed Dog Holder	1
7.	22637P24	Screw	1
8.	50640-18	Feed Eccentric, main	1
9.	SS8660612TP	Screw	2
10.	SS7090530SP	Screw	10
11.	50334Y	Oil Shield	1
12.	50334W	Oil Scraper	1
13.	50634C	Feed Bar Seal	1
14.	50637A	Guide Plate, left, rear	1
15.	50335BA	Guide Plate, right, rear	1
16.	50634D	Feed Bar Seal	1
17.	50637	Guide Plate, front	1



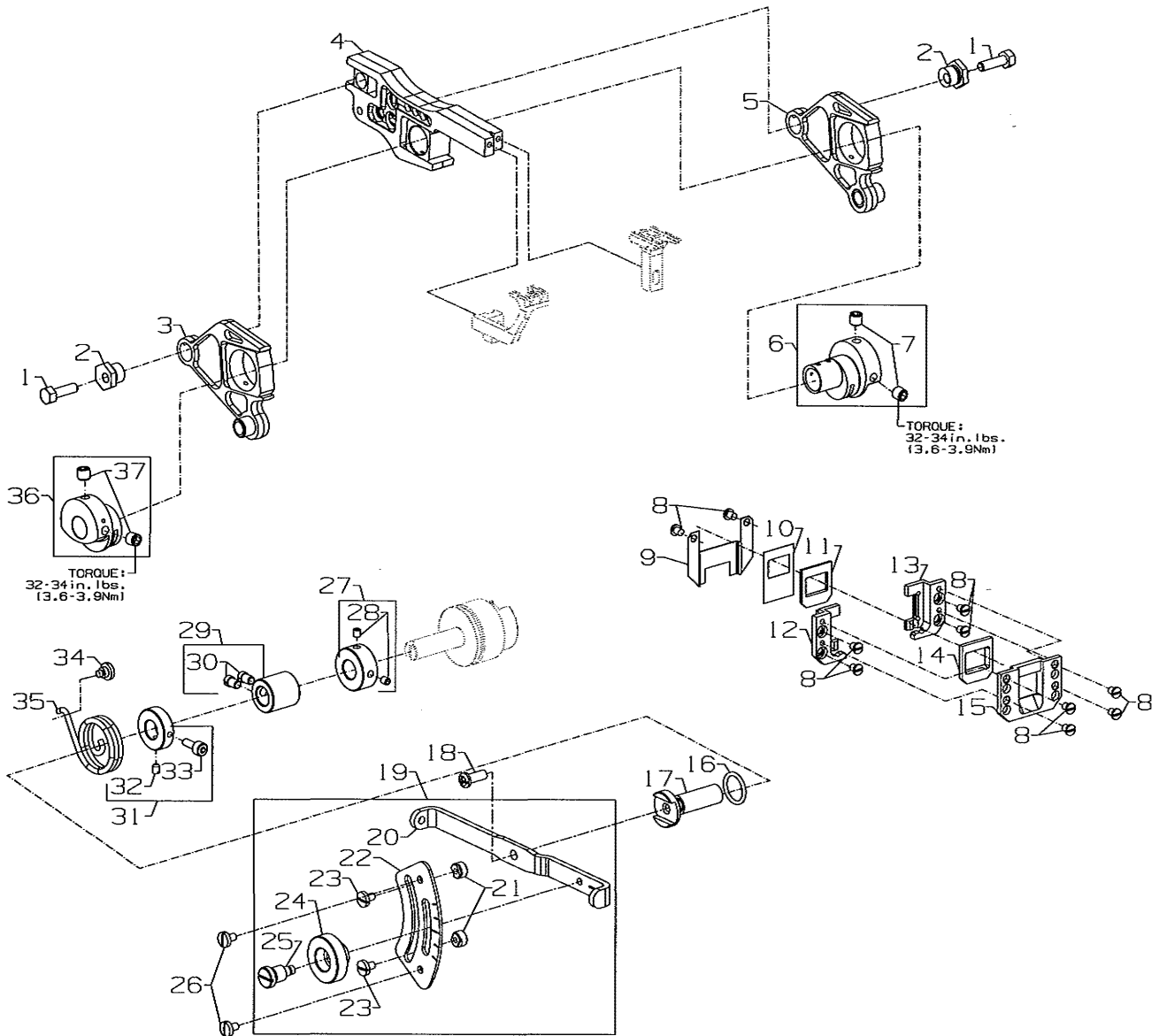

FEED DRIVE MECHANISM
FOR DIFFERENTIAL FEED

Ref. No.	Part No.	Description	Amt. Req.
1.	18-1432	Screw.....	2
2.	50334BD	Hex Eccentric Stud	2
3.	50334AW	Drive Fork Assembly	1
4.	50334BE	Feed Bar Assembly	1
5.	50334AX	Drive Fork Assembly, right	1
6.	50340D	Feed Eccentric, main	1
7.	SS8660612TP	Screw	2
8.	SS7090530SP	Screw	10
9.	50334Y	Oil Shield	1
10.	50334V	Oil Scraper	1
11.	50334BH	Feed Bar Seal	1
12.	50335AM	Guide Plate, left, rear	1
13.	50335BA	Guide Plate, right, rear	1
14.	50334J	Feed Bar Seal	1
15.	50335AN	Guide Plate, front	1
16.	RO681190100	"O" Ring	1
17.	50337J	Stem, for differential feed lever	1
18.	SS4121215SP	Screw, for stem	1
19.	29476UM	Differential Feed Lever Assembly	1
20.	50337H	Differential Feed Lever	1
21.	50337U	Stop	2
22.	50337K	Plate, for differential feed lever	1
23.	SS7090610SP	Screw	2
24.	B1647704000A	Knob, for differential feed lever	1
25.	50387	Screw	1
26.	SS7090610SP	Screw	2
27.	50337S	Collar	1
28.	SS8110422TP	Screw	2
29.	50337L	Coupling, for differential feed lever	1
30.	SS6110650TP	Screw	2
31.	50337R	Collar, for differential feed lever	1
32.	SS8090710SP	Screw	1
33.	SS6091022TP	Screw	1
34.	SP0550271TP	Screw, for spring	1
35.	50337M	Spring, for differential feed lever	1
36.	50340E	Feed Eccentric, differential	1
37.	SS8660612TP	Screw	2



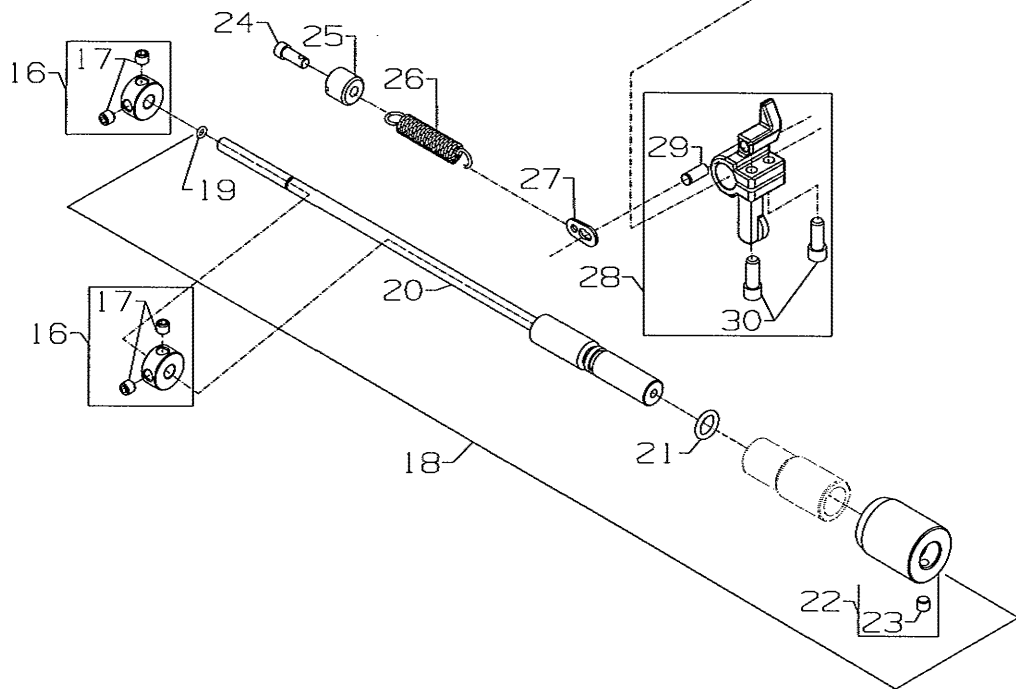
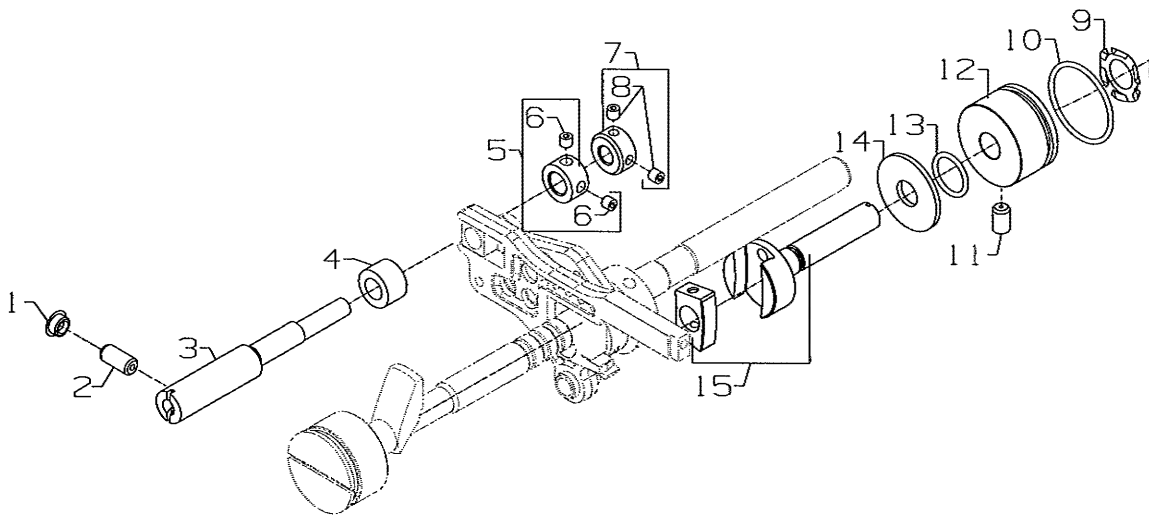

FEED DRIVE MECHANISM
FOR PLAIN FEED

Ref. No.	Part No.	Description	Amt. Req.
1.	TA075404RO	Plug, for eccentric shaft	1
2.	22591A	Screw, for eccentric shaft	1
3.	50334BC	Eccentric Shaft	1
4.	50674	Washer, for eccentric shaft	1
5.	50334BB	Collar, for eccentric shaft	1
6.	SS8110422TP	Screw, for collar	2
7.	50337T	Collar, for eccentric shaft	1
8.	SS8110422TP	Screw, for collar	2
9.	661-96	Spring Washer	1
10.	660-969	"O" Ring, for bushing	1
11.	SS8661012TP	Screw, for bushing	1
12.	35036F	Bushing, for stitch adjusting shaft	1
13.	660-220	"O" Ring, for stitch adjusting shaft	1
14.	35036AZ	Brake Pad	1
15.	50634G	Stitch Adjusting Shaft Assembly	1
16.	50335D	Collar	2
17.	22894P	Screw	4
18.	29476UF	Stitch Length Adjusting Rod Assembly	1
19.	660-980	"O" Ring, stitch control shaft	1
20.	50322AR	Shaft, for stitch control	1
21.	660-206	"O" Ring, for stitch control shaft	1
22.	50336Y	Stitch Knob, indicator	1
23.	SS8110422TP	Screw	1
24.	50335	Spring Retainer	1
25.	22714C	Screw, for spring retainer	1
26.	50355	Spring	1
27.	50335A	Spring Holder	1
28.	50336S	Stitch Control Lever	1
29.	661-35	Pin	1
30.	22596H	Screw	2



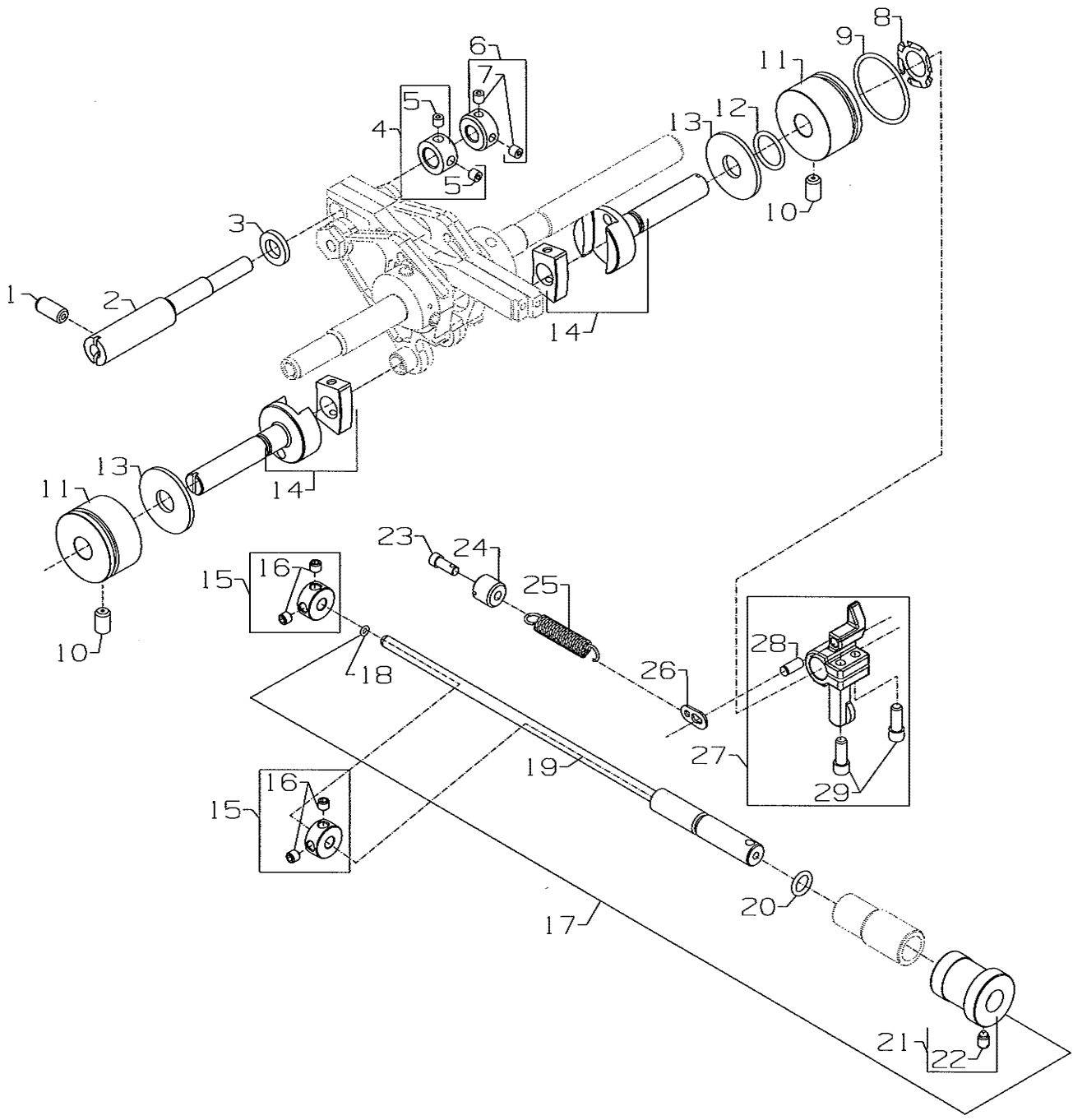

FEED DRIVE MECHANISM
FOR DIFFERENTIAL FEED

Ref. No.	Part No.	Description	Amt. Req.
1.	22591A	Screw, for eccentric shaft	1
2.	50334BC	Eccentric Shaft	1
3.	50674	Washer, for eccentric shaft	1
4.	50334BB	Collar, for eccentric shaft	1
5.	SS8110422TP	Screw, for collar	2
6.	50337T	Collar, for eccentric shaft	1
7.	SS8110422TP	Screw, for collar	2
8.	661-96	Spring Washer	1
9.	660-969	"O" Ring, for bushing	1
10.	SS8661012TP	Screw, for bushing	2
11.	35036F	Bushing, for stitch adjusting shaft	2
12.	660-220	"O" Ring, for stitch adjusting shaft	1
13.	35036AZ	Brake Pad	2
14.	50634G	Stitch Adjusting Shaft Assembly	2
15.	50335D	Collar	2
16.	22894P	Screw	4
17.	29476UF	Stitch Length Adjusting Rod Assembly	1
18.	660-980	"O" Ring, stitch control shaft	1
19.	50322AR	Shaft, for stitch control	1
20.	660-206	"O" Ring, for stitch control shaft	1
21.	50336Y	Stitch Knob, indicator	1
22.	SS8110422TP	Screw	1
23.	50335	Spring Retainer	1
24.	22714C	Screw, for spring retainer	1
25.	50355	Spring	1
26.	50335A	Spring Holder	1
27.	50336S	Stitch Control Lever	1
28.	661-35	Pin	1
29.	22596H	Screw	2



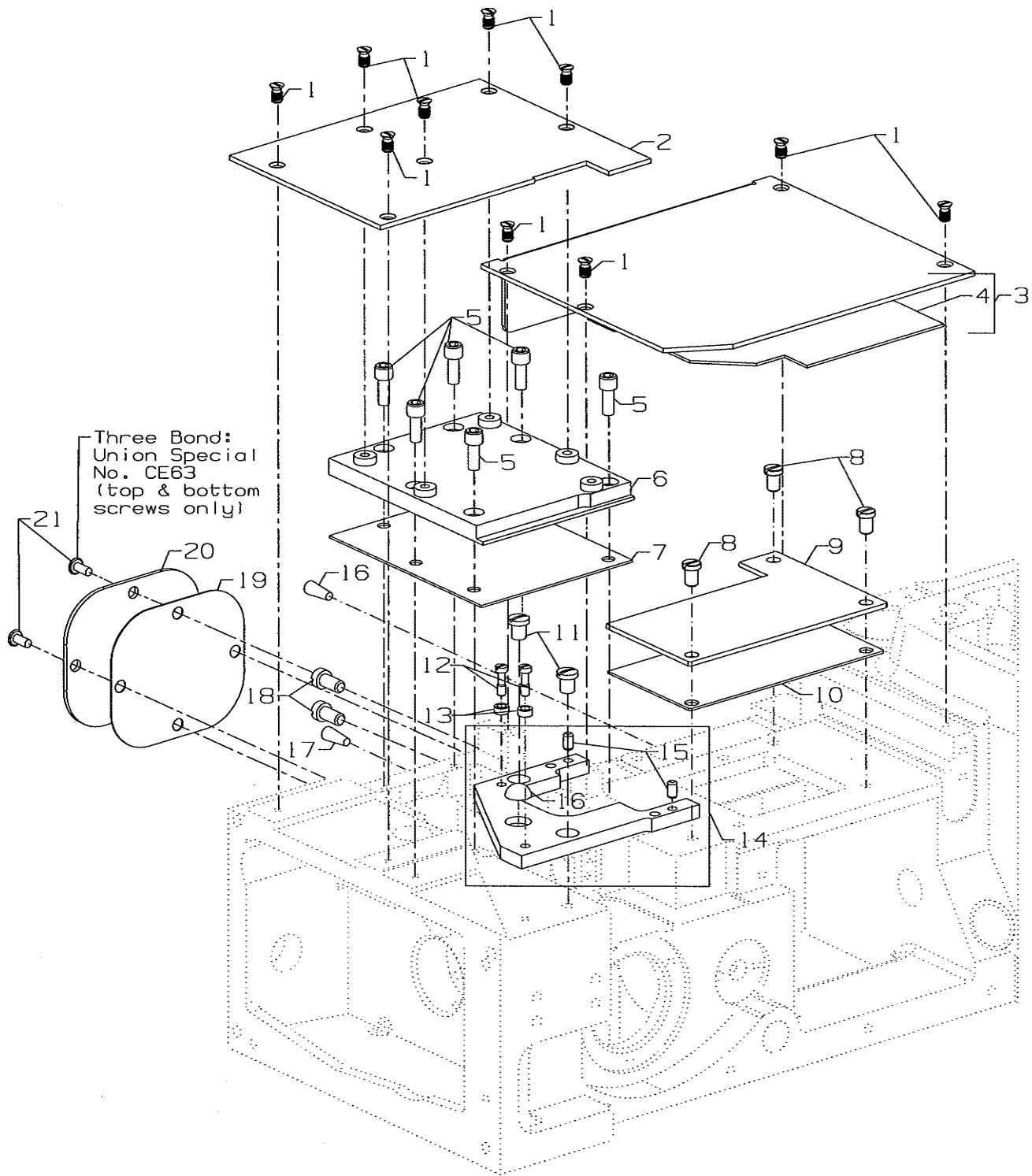

COVERS, LOWER BED

Ref. No.	Part No.	Description	Amt. Req.
1.	18-1448	Screw	11
2.	50601F	Cloth Plate, left	1
3.	50601E	Cloth Plate, right	1
4.	50303B	Acoustic Pad	1
5.	SS6121212TP	Screw, for cover	6
6.	50382CP	Cover, for feed chamber	1
7.	50382CS	Gasket	1
8.	22839C	Screw, for cover	3
9.	50382JR	Cover, for dry chamber	1
10.	50384K	Gasket, for dry chamber cover	1
11.	SS7150740SP	Screw	2
12.	22587N	Screw	2
13.	35036AE	Ferrule, Locating	2
14.	50380D	Throat Plate Support, complete	1
15.	51280K	Pin	1
16.	660-939	Rubber Bumper, for Throat Plate Support	1
17.	C067D	Cork	2
18.	22517	Screw, for bed	2
19.	50382CR	Gasket	1
20.	50382CL	Cover, rear, for feed chamber,	1
21.	SS4120615SP	Screw, for cover	2
-	CE63	Three Bond Adhesive, (not shown), for screw	-



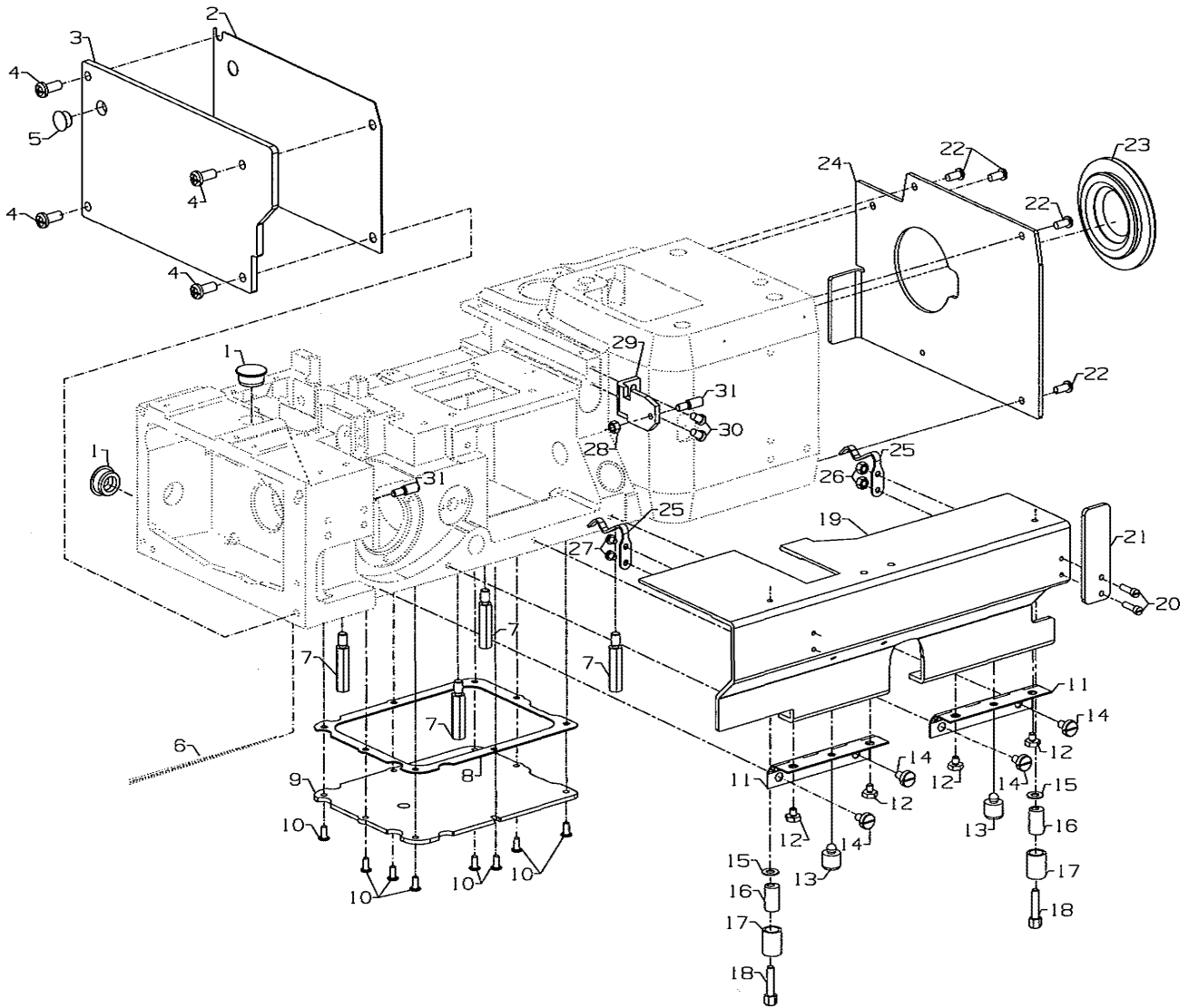

COVERS, LOWER BED

FOR PLAIN FEED

Ref. No.	Part No.	Description	Amt. Req.
1.	50393HB	Plug, for bed	2
2.	50684A	Quad Ring, for left end cover	1
3.	50682B	Left End Cover	1
4.	SS4151415SP	Screw	4
5.	50393HA	Plug	1
6.	WO3	Oil Wick, for needle guard	1
7.	22841U	Machine Support Stud	4
8.	50383G	Gasket, for chamber cover	1
9.	50382CG	Dry Chamber Cover	1
10.	SS7090850SP	Screw	8
11.	50378S	Hinge	2
12.	SS9110543CP	Screw	4
13.	660-1020	Rubber Bumper	2
14.	SS6120930TP	Screw	4
15.	20	Washer	2
16.	50382T	Stop, for front cover	2
17.	50393W	Rubber Bumper	2
18.	22519J	Screw	2
19.	50682D	Swing Down Cover	1
20.	22729D	Screw	2
21.	50363CH	Lever	1
22.	SS4121015SP	Screw	4
23.	50393HU	Plug, right end, non-synchronizer	1
24.	50382CJ	Cover, for drive belt	1
25.	50332A	Latch Spring	2
26.	39250J	Nut	2
27.	22513D	Screw	2
28.	35569J	Nut	1
29.	50332B	Support Block	1
30.	SS7120710SP	Screw	2
31.	22799AH	Spring Latch Stud	2



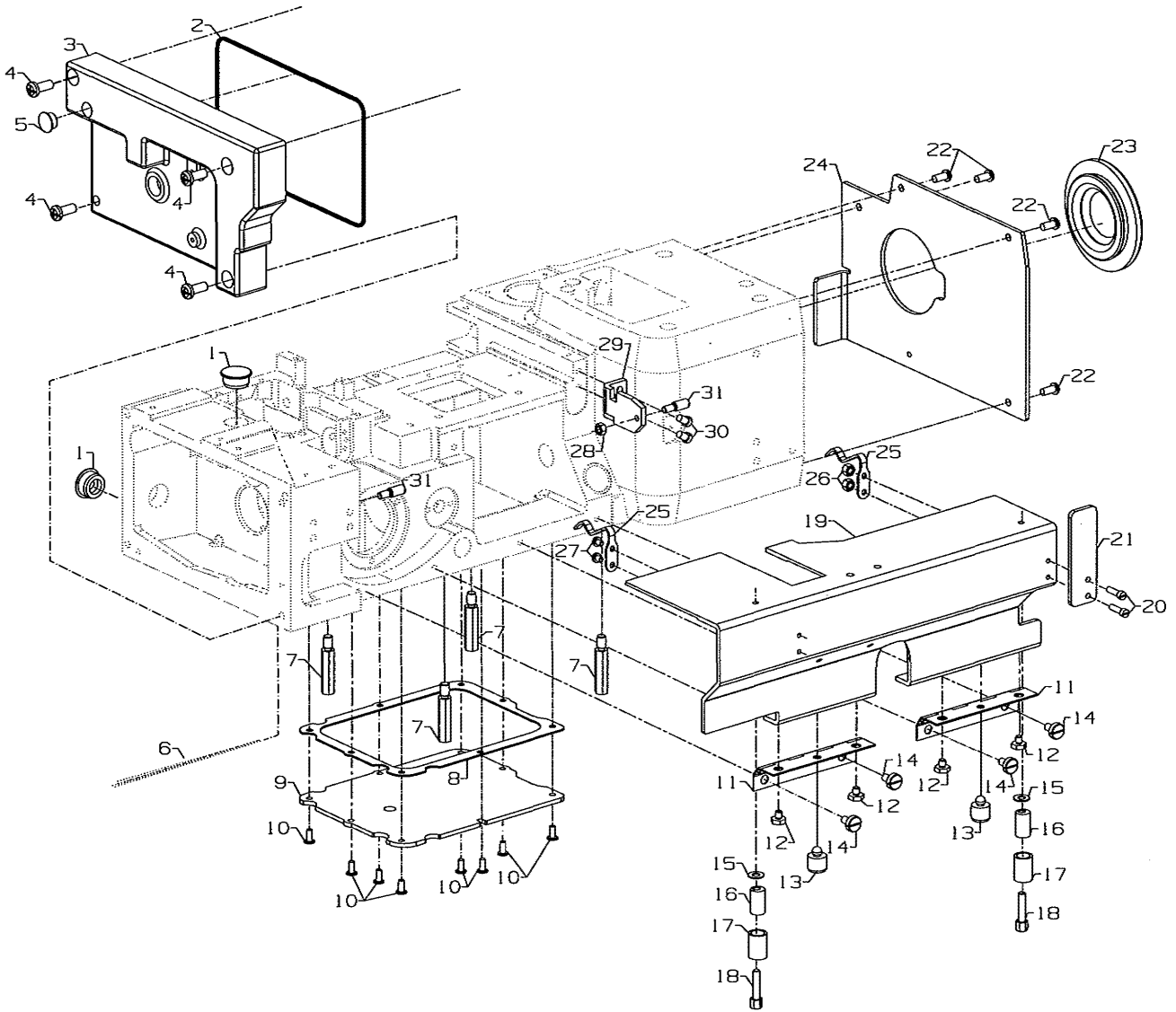

COVERS, LOWER BED

FOR DIFFERENTIAL FEED

Ref. No.	Part No.	Description	Amt. Req.
1.	50393HB	Plug, for bed	2
2.	50382CM	Quad Ring, for left end cover	1
3.	50382CH	Left End Cover	1
4.	SS4151415SP	Screw	4
5.	50393HA	Plug	1
6.	WO3	Oil Wick, for needle guard	1
7.	22841U	Machine Support Stud	4
8.	50383G	Gasket, for chamber cover	1
9.	50382CG	Dry Chamber Cover	1
10.	SS7090850SP	Screw	8
11.	50378S	Hinge	2
12.	SS9110543CP	Screw	4
13.	660-1020	Rubber Bumper	2
14.	SS6120930TP	Screw	4
15.	20	Washer	2
16.	50382T	Stop, for front cover	2
17.	50393W	Rubber Bumper	2
18.	22519J	Screw	2
19.	50682D	Swing Down Cover	1
20.	22729D	Screw	2
21.	50363CH	Lever	1
22.	SS4121015SP	Screw	4
23.	50393HU	Plug, right end, non-synchronizer	1
24.	50382CJ	Cover, for drive belt	1
25.	50332A	Latch Spring	2
26.	39250J	Nut	2
27.	22513D	Screw	2
28.	35569J	Nut	1
29.	50332B	Support Block	1
30.	SS7120710SP	Screw	2
31.	22799AH	Spring Latch Stud	2



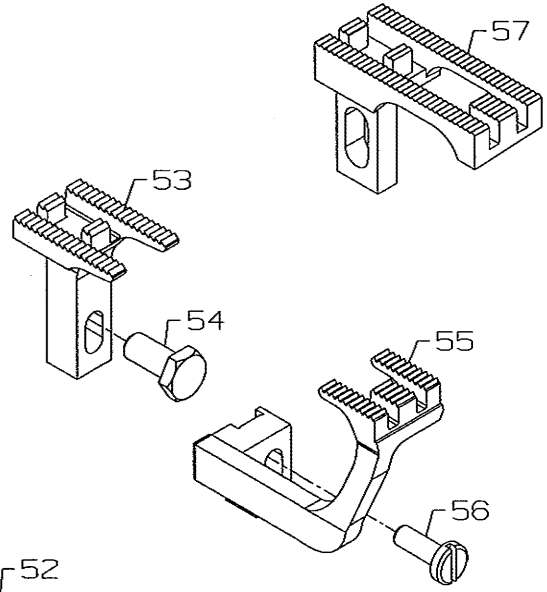
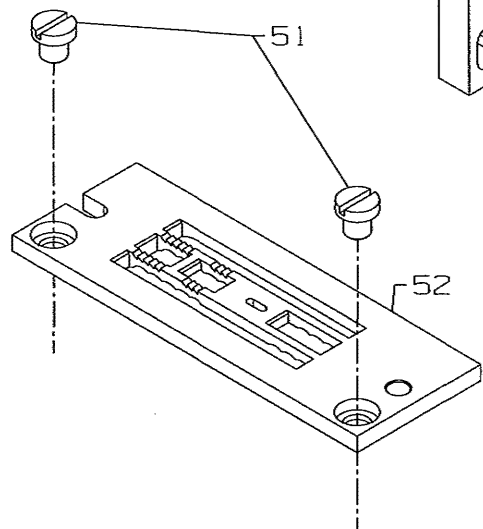
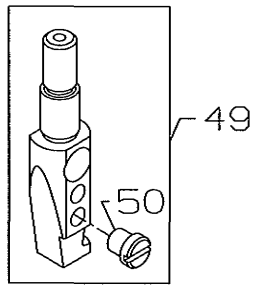
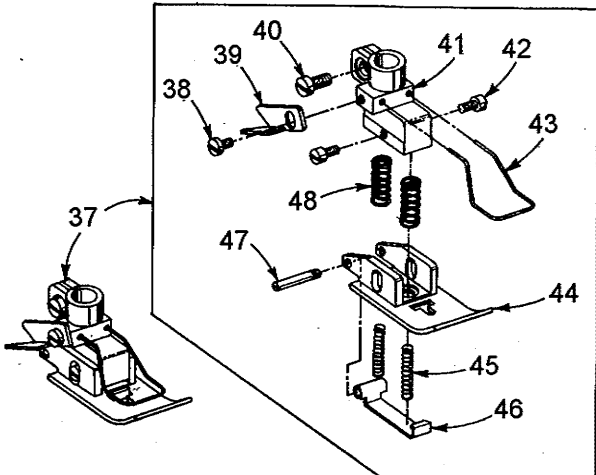
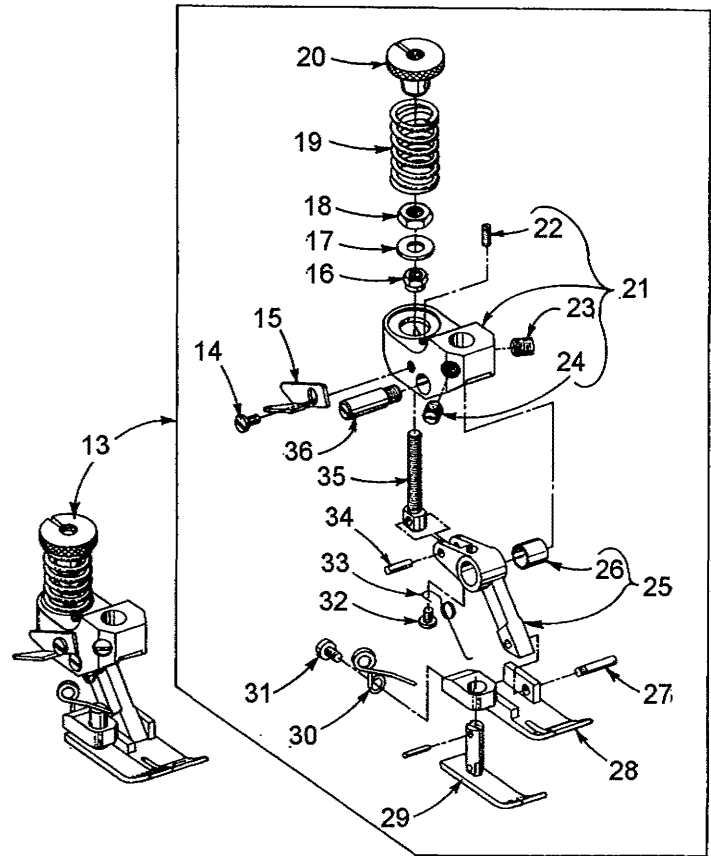
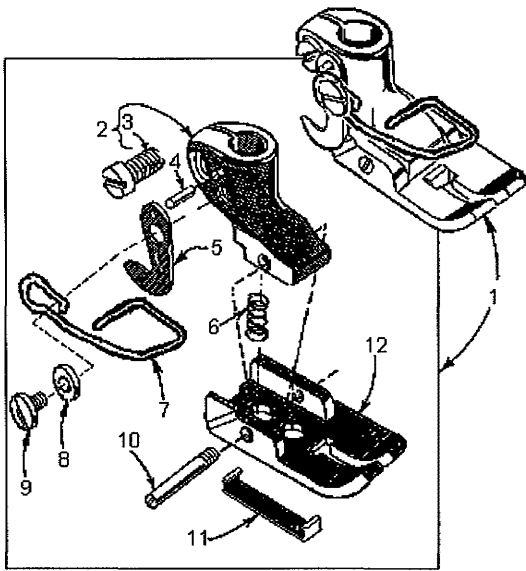

SEWING PARTS

Ref. No.	Part No.	Description	Amt. Req.
1.	G51320	Presser Foot Assembly, for sewing comb., (see chart)	1
2.	G51330C	Presser Foot Shank	1
3.	91	Screw	1
4.	1741A	Pin	1
5.	1741B	Knife	1
6.	51390	Spring	1
7.	G21695P	Finger Guard	1
8.	41358	Washer	1
9.	22768	Screw	1
10.	1025104	Pin	1
11.	G51330B	Chaining Section	1
12.	G51330A	Presser Foot Bottom	1
13.	56320H	Presser Foot Assembly, for sewing comb., (see chart)	1
14.	604	Screw	1
15.	52930AC	Chain Cutting Knife	1
16.	51430F	Nut	1
17.	56330AU	Washer	1
18.	41071G	Lock Nut	1
19.	56330AD	Spring	1
20.	56330AH	Nut	1
21.	56330AK	Presser Foot Yoke	1
22.	22785	Set Screw	1
23.	22560B	Screw	1
24.	88	Screw	1
25.	56330AN	Presser Foot Link	1
26.	56330AP	Bushing	1
27.	22799G	Screw	1
28.	56330AL	Presser Foot Bottom	1
29.	56330AM	Yielding Section	1
30.	56330AR	Spring, for yielding section	1
31.	604	Screw	1
32.	73A	Screw	1
33.	56330AX	Spring, tilting	1
34.	56330AJ	Pin	1
35.	56330AG	Screw	1
36.	56330AF	Screw	1
37.	C50020	Presser Foot Assembly, for sewing comb., (see chart)	1
38.	604	Screw	1
39.	52930AC	Knife, chain cutter	1
40.	22562	Screw	1
41.	C50030	Shank, presser foot	1
42.	22784M	Screw	1
43.	C50031C	Guard, finger	1
44.	C50030A	Presser Foot Bottom	1
45.	C50030D	Spring	2
46.	C50030AB	Yielding Section	1
47.	C50030C	Spring	2
48.	22799B	Screw, hinge	1
49.	50618	Needle Head	1
50.	SS6080360SP	Screw	1
51.	22570	Screw, for throat plate	2
52.	-----	Throat Plate, for sewing comb., (see chart)	1
53.	-----	Main Feed Dog, for differential feed, (see chart)	1
54.	18-677	Screw, for main feed dog	1
55.	-----	Differential Feed Dog, for sewing comb., (see chart)	1
56.	SS7091110TP	Screw, for differential feed dog	1
57.	-----	Main Feed Dog, for plain feed, (see chart)	1

SEWING COMB.	MODEL	NEEDLE HEAD	PRESSER FOOT ASSEMBLY	THROAT PLATE	FEED DOG MAIN	FEED DOG DIFFERENTIAL
FS01-1	FS311S01-1M	50618	G51320	50624A	C50005G	
FS02-2	FS311S02-1M		56320R			
FS11-1	FS311S11-1M		56320F	50624	C50005F	
FS12-1	FS311S12-1M		56320H			
FS13-1	FS311S13-1M		56320E	50624B	56305C	
FS14-1	FS311S14-1M		C50020	50624	C50005F	
FS21-1	FS312S21-1M		C50020		50605	



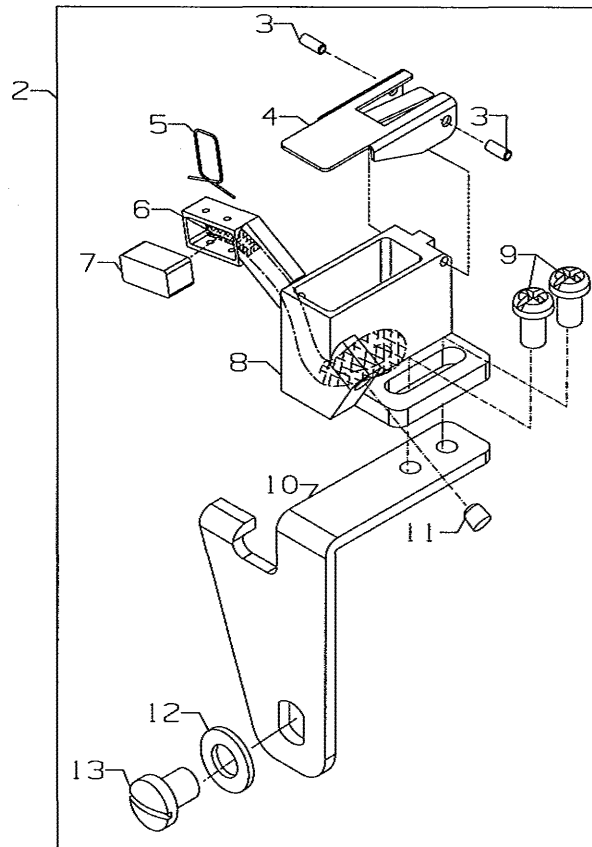
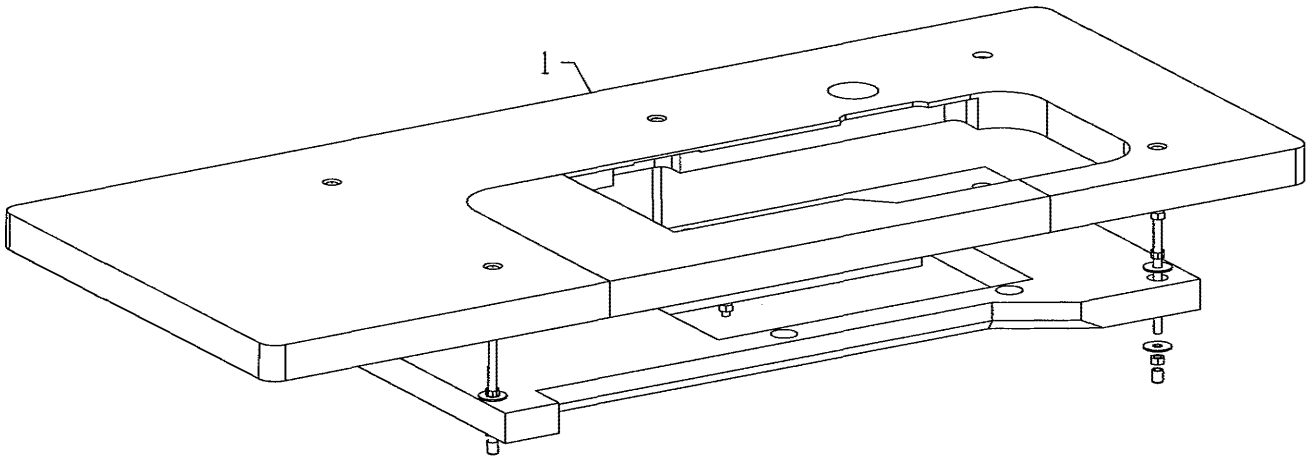

TABLING AND NEEDLE DIPPER ASSEMBLY
(EXTRA SEND CHARGE)

Ref. No.	Part No.	Description	Amt. Req.
1.	21371AAE48	Table Board, for differential feed machines	1
-	21317AAH48	Table Board, for plain feed machines	1
2.	29476RZ	Needle Dipper Assembly	1
3.	PS0160042KH	Roll Pin	2
4.	50393JD	Needle Dipper Cover	1
5.	50393GS	Wire, for needle dipper	1
6.	CQ202000000	Oil Wick, for needle dipper	1
7.	50393GK	Felt, for needle dipper	1
8.	50393JC	Needle Dipper	1
9.	SS4090615SP	Screw, for needle dipper	2
10.	50393GP	Silicone Oil Tank Holder	1
11.	50393GG	Plug	1
12.	WP0531000SD	Washer	1
13.	SS4120615SP	Screw, for needle dipper holder	1



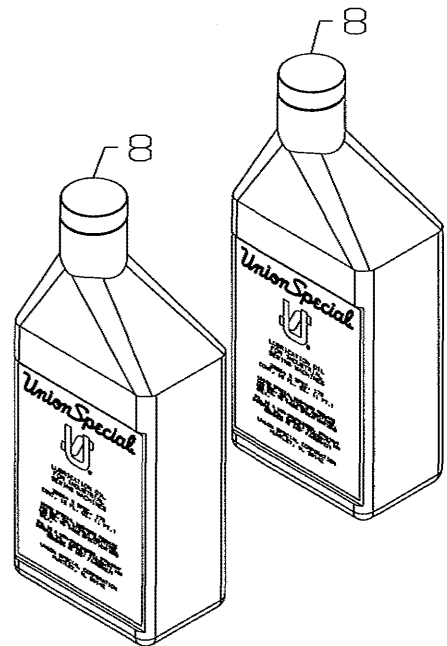
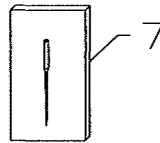
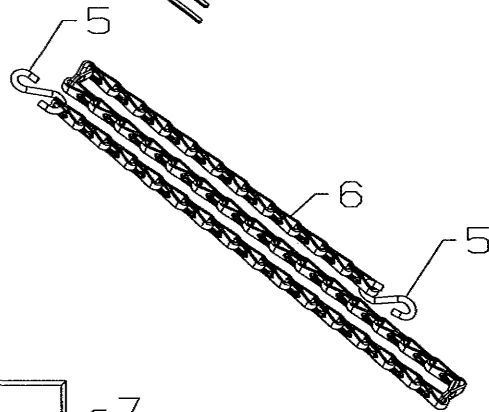
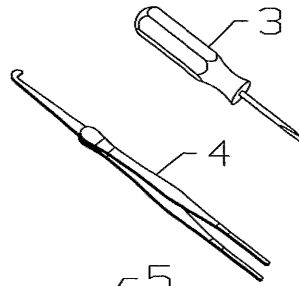
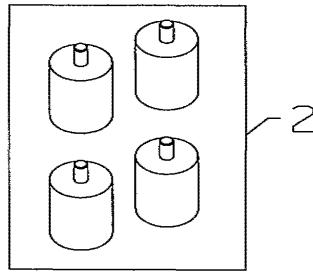
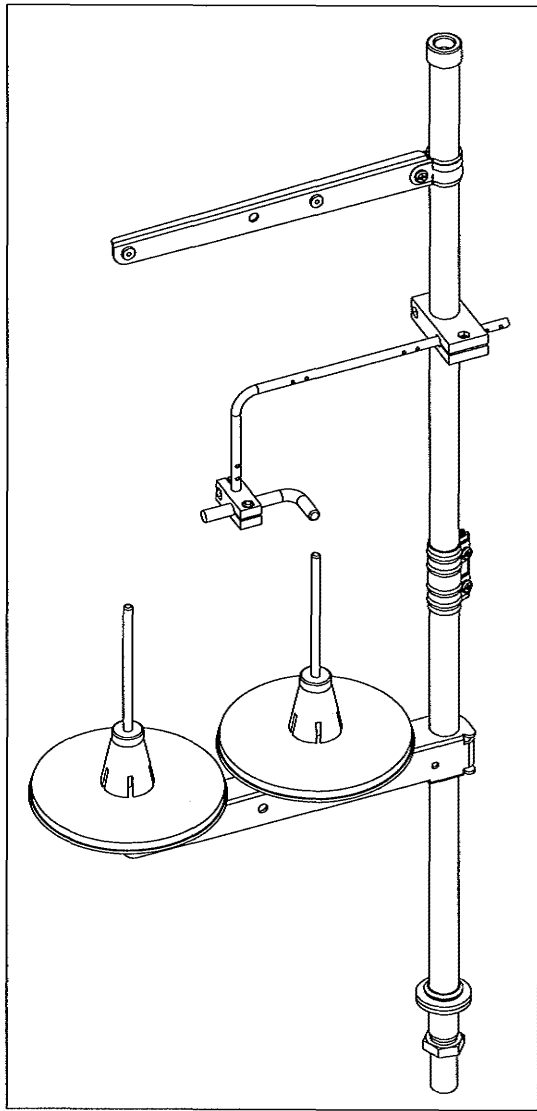

ACCESSORIES

Ref. No.	Part No.	Description	Amt. Req.
1.	21101W2	Thread Stand	1
2.	35095B	Isolator	4
3.	G21201	Screw Driver, for needle head	1
4.	660-240	Thread Tweezer	1
5.	660-264	S-Hook	2
6.	421D34	Chain	1
7.	128GBS075/029	Needles, (package of 10)	1
8.	28604R	Oil, (1 pint)	2



NUMERICAL INDEX OF PARTS

<u>Part No.</u>	<u>Page No.</u>	<u>Part No.</u>	<u>Page No.</u>	<u>Part No.</u>	<u>Page No.</u>	<u>Part No.</u>	<u>Page No.</u>	<u>Part No.</u>	<u>Page No.</u>
1025104	55	35036AE	49	50336Y	45, 47	50382CL	49	50393JW	19
11071602	27	35036AZ	45, 47	50337H	43	50382CM	53	50393JZ	19
11071701	27	35036BS	17	50337J	43	50382CP	49	50393KF	33
11550209	25	35036F	45, 47	50337K	43	50382CR	49	50393KH	33
11843208	33	35095B	59	50337L	43	50382CS	49	50393KM	33
12124202	23	35569J	51, 53	50337M	43	50382FW	29	50393W	51, 53
128GBS075/029	59	39250J	51, 53	50337R	43	50382FX	29	50601E	49
13765607	33	402	25	50337S	43	50382FY	29	50601F	49
158B	23	41071G	55	50337T	45, 47	50382FZ	29	50618	55
1741A	55	41358	39, 55	50337U	43	50382GB	29	50622D	31
1741B	55	421D34	59	50338	19	50382GM	29	50622E	31
18-1432	41, 43	50303B	49	50338A	19	50382JR	49	50623	39
18-1448	49	50304H	39	50340D	43	50382T	51, 53	50634	41
18-677	55	50304K	39	50340E	43	50383AE	29	50634C	41
20	51, 53	50304L	39	50342AX	31	50383E	39	50634D	41
21101W2	59	50309F	35	50342BE	21	50383F	39	50634E	41
21317AAH48	57	50313	35	50342BJ	35	50383G	51, 53	50634G	45, 47
21371AAE48	57	50313J	35	50342BK	35	50384A	33	50637	41
22-348	39	50314E	35	50342BP	35	50384K	49	50637A	41
22513D	51, 53	50314F	35	50342BS	31	50384L	29	50640-18	41
22517	49	50317B	19	50344AM	35	50387	43	50642	35
22517B	29	50317C	29	50344BC	17	50391	21	50643A	27
22519J	51, 53	50321F	21	50344BE	17	50392AB	17	50643B	27
22560B	55	50321G	31	50344BF	17	50392AE	23	50654	17
22562	55	50322AF	21	50344BU	17	50392AV	25	50654A	17
22565	35	50322AG	31	50344E	17	50392BC	25	50657	39
22570	55	50322AL	31	50345W	19	50392S	23	50663	23
22571E	33	50322AR	45, 47	50351A	19	50392W	25	50674	45, 47
22571L	17	50323B	39	50352	19	50392X	25	50682B	51
22587N	49	50323H	39	50354F	19	50392Z	25	50682D	51, 53
22591A	45, 47	50323P	19	50354L	37	50393-140	33	50683A	23
22596H	45, 47	50325AE	37	50355	45, 47	50393-170	33	50684A	51
22637P24	41	50325AF	37	50355AM	19	50393-27	33	50692B	25
22652B10	35	50330CZ	17	50355AN	19	50393-40	33	50692G	25
22653J8	35	50332A	51, 53	50355AR	27	50393-447	33	50692H	23
22714C	45, 47	50332B	51, 53	50357AA	27	50393-70	33	50696	29
22729D	51, 53	50332S	33	50357AP	27	50393EB	33	51280K	49
22768	55	50332U	17	50357AR	23	50393EU	29	51390	55
22784M	55	50332V	27	50357AS	23	50393EW	29	51430F	55
22785	55	50333A	31	50357V	23	50393EX	33	51492	39
22799AH	51, 53	50334A	41	50357W	39	50393EY	17	51959B	39
22799B	55	50334AW	43	50357Y	23	50393FR	33	51959D	39
22799G	55	50334AX	41, 43	50358X	19	50393FS	33	51959K	39
22837	23	50334BB	45, 47	50363CH	51, 53	50393FT	33	51959L	39
22839C	49	50334BC	45, 47	50366	23	50393FU	17	52930AC	55
22841U	51, 53	50334BD	41, 43	50366A	23	50393FV	33	52958D	39
22875N	25	50334BE	43	50366G	23	50393GB	33	56320H	55
22894C	39	50334BH	43	50368A	37	50393GD	33	56330AD	55
22894P	45, 47	50334J	43	50368E	37	50393GE	17	56330AF	55
258A	33	50334V	43	50368T	37	50393GG	57	56330AG	55
28604R	59	50334W	41	50368V	37	50393GK	57	56330AH	55
29476RZ	57	50334Y	41, 43	50368W	37	50393GP	57	56330AJ	55
29476TC	19	50335	45, 47	50373DA	37	50393GS	57	56330AK	55
29476TG	23	50335A	45, 47	50374	31	50393HA	51, 53	56330AL	55
29476TK	27	50335AF	27	50377R	39	50393HB	29, 51, 53	56330AM	55
29476TT	27	50335AG	27	50378S	51, 53	50393HH	23	56330AN	55
29476UF	45, 47	50335AH	27	50380D	49	50393HJ	33	56330AP	55
29476UH	31	50335AK	31	50381	27	50393HK	33	56330AR	55
29476UJ	37	50335AM	43	50381B	27	50393HL	33	56330AU	55
29476UK	39	50335AN	43	50381E	17	50393HN	33	56330AX	55
29476UM	43	50335BA	41, 43	50381F	27	50393HR	33	56358B	23
29476US	33	50335BB	31	50381G	27	50393HU	51, 53	56358C	23
29476UT	33	50335BD	21	50382CG	51, 53	50393JC	57	56358D	23
29476VN	19	50335D	45, 47	50382CH	53	50393JD	57	56392G	25
34393D	33	50336S	45, 47	50382CJ	51, 53	50393JP	19	56392H	25



NUMERICAL INDEX OF PARTS

<u>Part No.</u>	<u>Page No.</u>	<u>Part No.</u>	<u>Page No.</u>	<u>Part No.</u>	<u>Page No.</u>
56392R	25	G21201	59	SS7121410TP	25
57865	25	G21695P	55	SS7150740SP	49
57892K	25	G51320	55	SS7660520SP	21, 31
604	55	G51330A	55	SS7681410TP	21
605A	23	G51330B	55	SS8090710SP	43
652C16	29	G51330C	55	SS8110422TP	19, 27
660-1014	27	LA452	29	SS8110422TP	37, 43
660-1020	51, 53	NS6110310SP	33	SS8110422TP	45, 47
660-1043	21	NS6110420SP	25	SS8660410SP	31
660-1062	31	NS6150310SP	27	SS8660612TP	21, 31
660-1087	21	NS6620320SP	29	SS8660612TP	33, 35
660-206	45, 47	PS0160042KH	59	SS8660612TP	41, 43
660-220	45, 47	PS0400142KH	17	SS8661012TP	21, 31
660-240	59	RE0500000K0	27	SS8661012TP	45, 47
660-264	59	RM2871B	33	SS8681412TP	21
660-283A	25	RO068190100	27	SS9080410SP	39
660-455	35	RO681190100	43	SS9090420TP	37
660-739	27	SD0380551SL	23	SS9110543CP	51, 53
660-893	35	SD0630275SP	39	SS9111010SP	39
660-934	31	SD0640323TP	29	SS9151740CP	27
660-939	49	SD0790303SP	27	TA075404RO	45
660-969	45, 47	SP0550271TP	43	TA1050504RO	29
660-979	35	SQ1110401MZ	17	TA1100604RO	29
660-980	45, 47	SQ1110402MZ	33	W03	51, 53
661-259B	19	SS1110640SL	29	WPO531000SD	57
661-261	21	SS1121010SP	23	WS0410002KP	23
661-262	21	SS4080620TP	19	WS0631510KP	33
661-35	45, 47	SS4090615SP	57	WZ0640200KP	39
661-96	45, 47	SS4090815SP	23, 33	WZ0641510KP	29
662-212	29	SS4091015SP	33		
666-328	19	SS4120615SP	29		
666-330	25	SS4120615SP	49, 57		
667J33	35	SS4120915SP	23		
73A	55	SS4120915SP	25, 29		
77B	39	SS4121015SP	51, 53		
88	55	SS4121215SP	27		
91	55	SS4121215SP	29, 43		
98A	23	SS4121615SP	29		
99682XC	29	SS4151415SP	51, 53		
99682XCB	29	SS6080360SP	55		
998-358F	33	SS6090440SP	19		
B1647704000A	43	SS6090620SP	19		
B3103804000	25	SS6091022TP	43		
B3112704000	25	SS6110610TP	27, 39		
B3120352000	25	SS6110650TP	43		
B3120704000	25	SS6120930TP	51, 53		
B3121804000	25	SS6121010SP	19		
B3126012000	25	SS6121212TP	49		
B3530555000	29	SS6151812TP	33		
C067D	49	SS6151920SP	27		
C50020	55	SS6153040SP	27		
C50030	55	SS7060310SP	39		
C50030A	55	SS7080520SP	19, 39		
C50030AB	55	SS7090520SP	25		
C50030C	55	SS7090530SP	41, 43		
C50030D	55	SS7090610SP	23, 43		
C50031C	55	SS7090850SP	51, 53		
C50044E	23	SS7090910TP	23		
C50056B	27	SS7091110TP	55		
C50056J	27	SS7092110TP	39		
CE27	19	SS7111120TP	19, 21		
CE49	27	SS7120640SP	23, 29		
CE59	19	SS7120710SP	23, 33		
CE63	19, 35, 49	SS7120710SP	51, 53		
CQ20200000	57	SS7120910SP	35		



NOTES



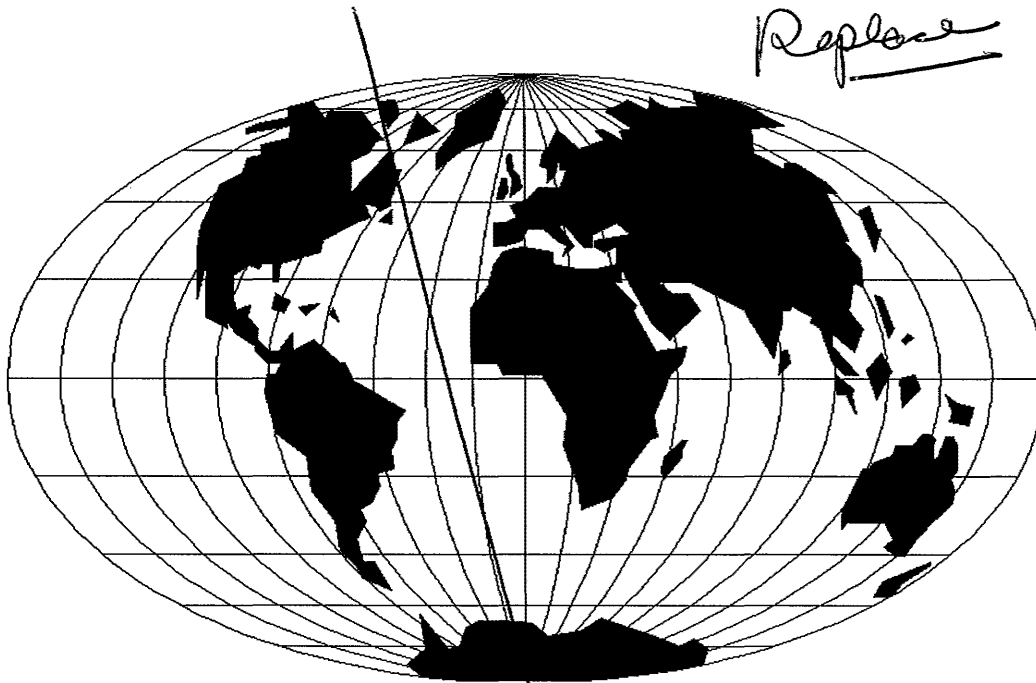

Replace

WORLDWIDE SALES AND SERVICE

Union Special Corporation maintains sales and service facilities throughout the world. These offices will aid you in the selection of the right sewing equipment for your particular operation. Union Special Corporation representatives and service technicians are factory trained and are able to serve your needs promptly and efficiently. Whatever your location, there is a qualified representative to serve you.

Corporate Office: One Union Special Plaza
Huntley, IL 60142
Phone: 847•669•5101
Fax: 847•669•4454

European Distribution Center: Union Special GmbH
Raiffeisenstrasse 3
D-71696 Möglingen, Germany
Tel: 49•07141•247•0
Fax: 49•07141•247•100

Brussels, Belgium
Charlotte, N.C.
El Paso, TX
Hong Kong, China
Huntley, IL
Leicester, England
Lille, France
Miami, FL
Milan, Italy
Möglingen, Germany
Montreal, Quebec
Osaka, Japan
Santa Fe Springs, CA

Other Representatives throughout all parts of the world.



Union Special
INDUSTRIAL SEWING EQUIPMENT